

Montageanleitung Installation instructions Instructions de montage Montagehandleiding

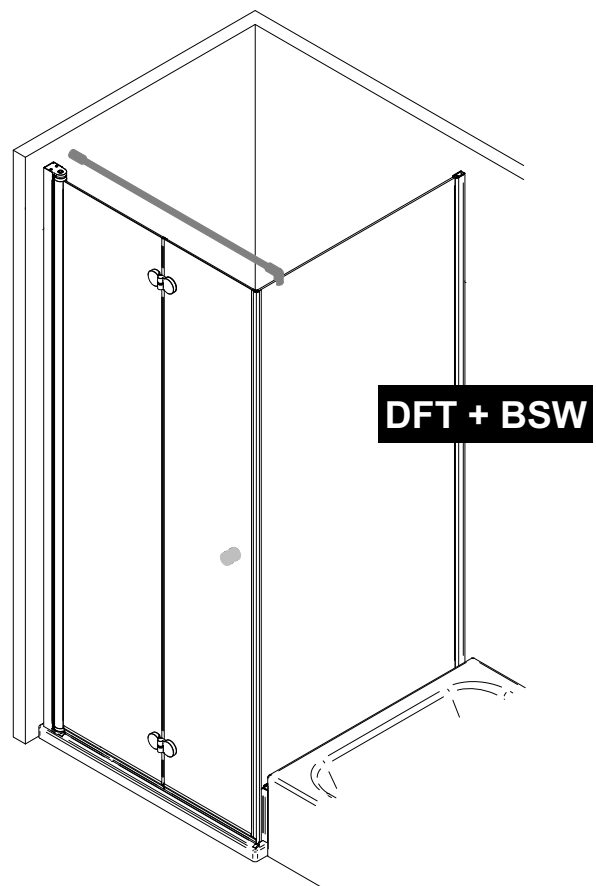

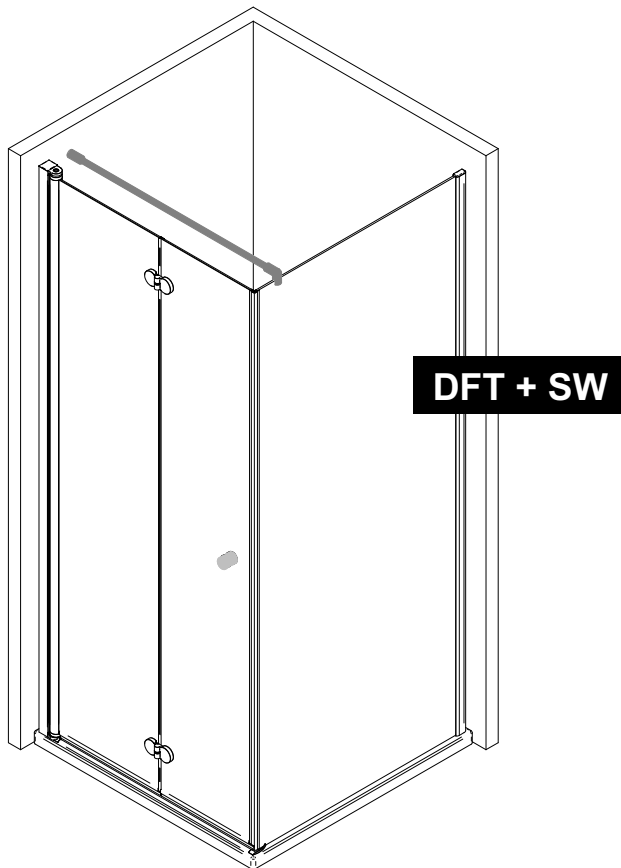

DFT

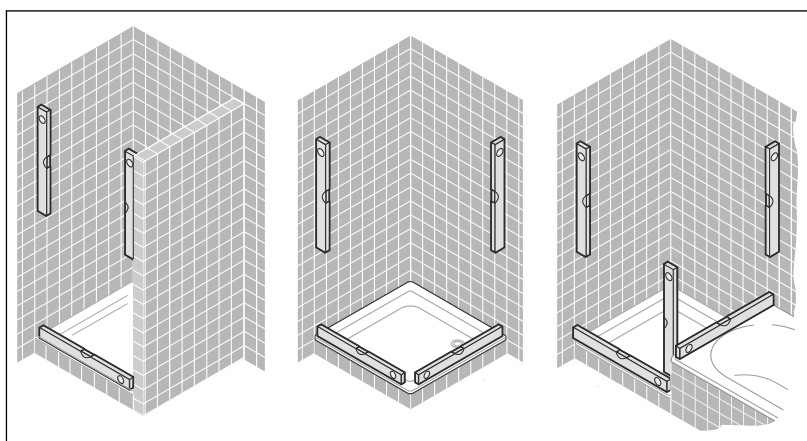
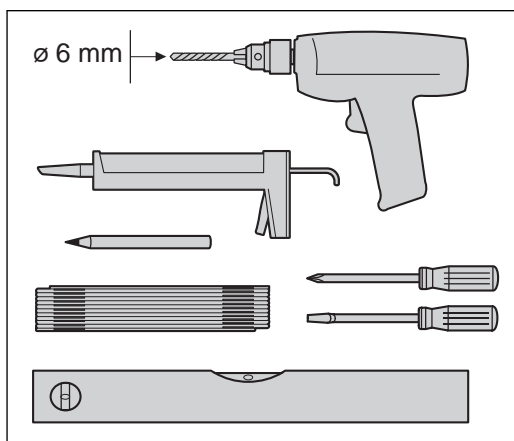
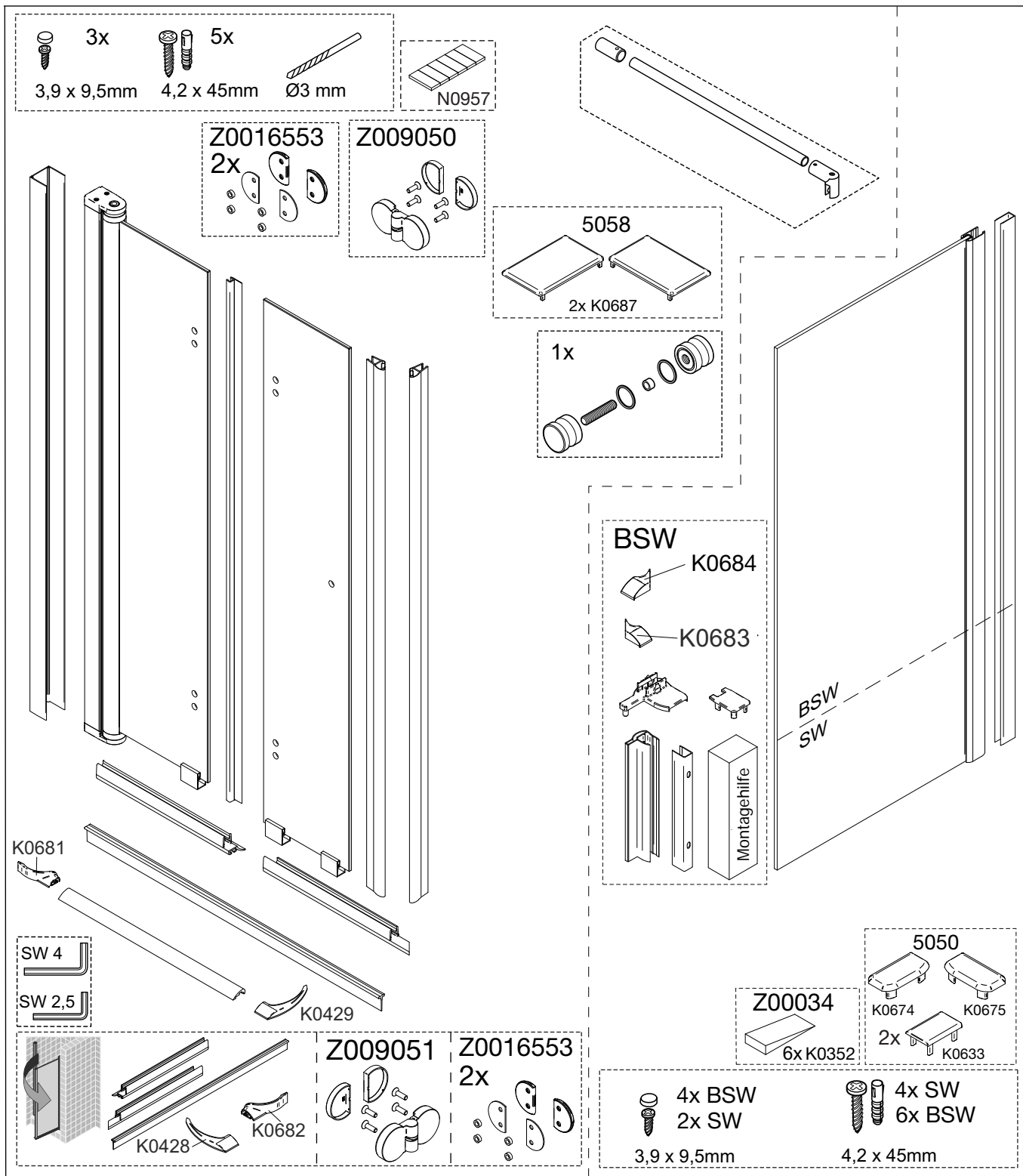
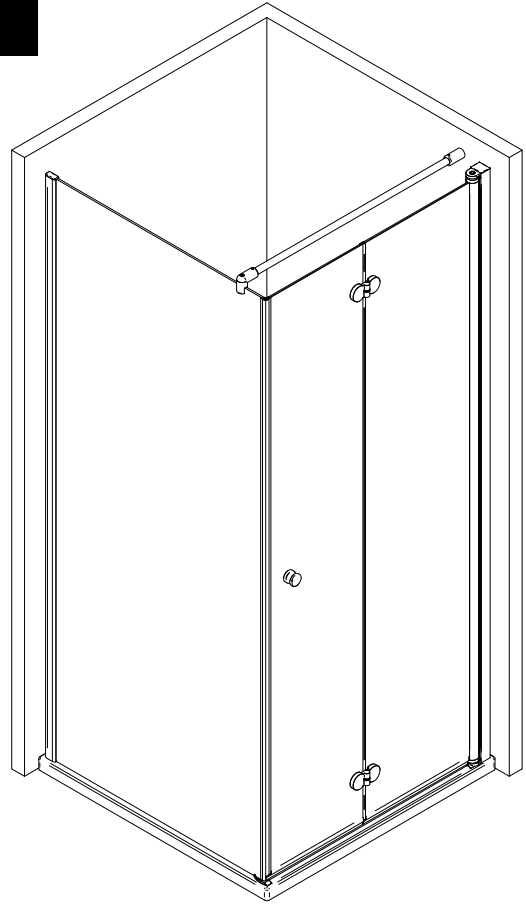
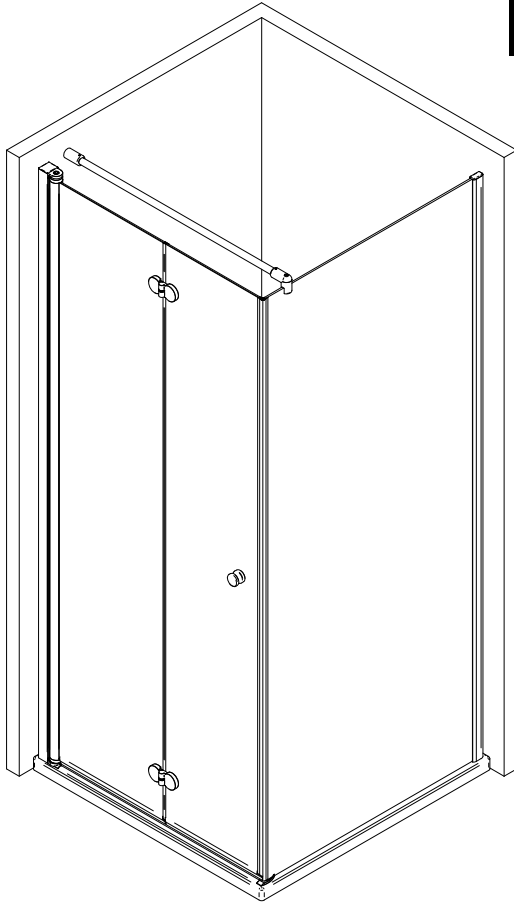

1

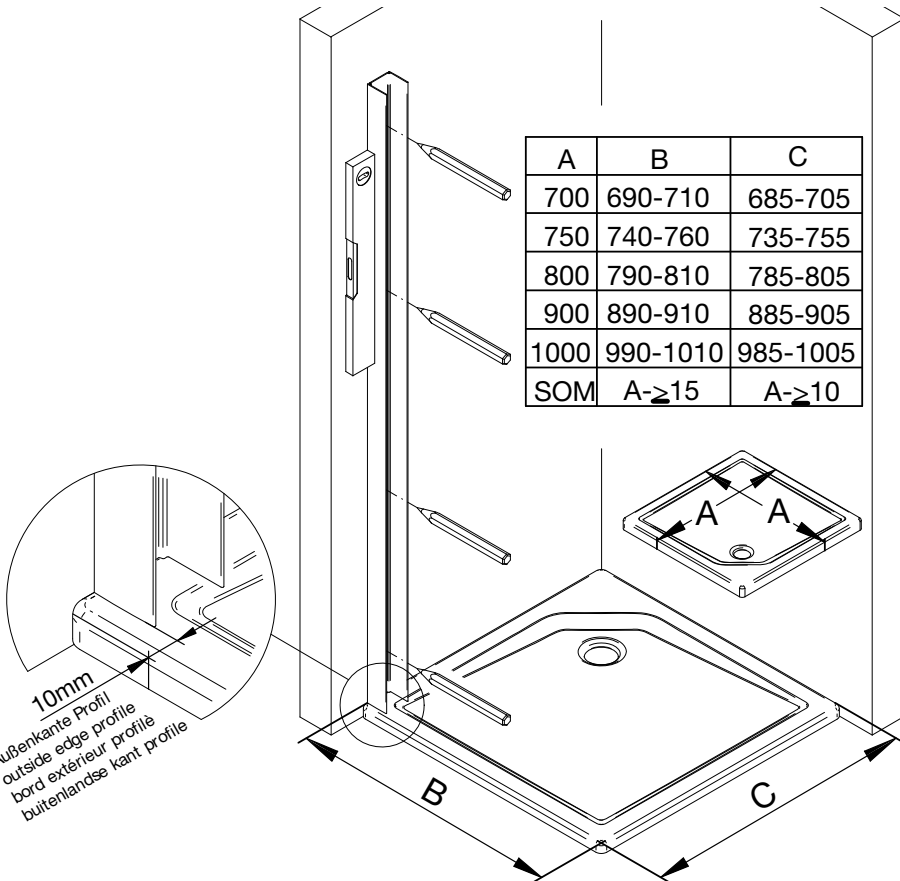

2

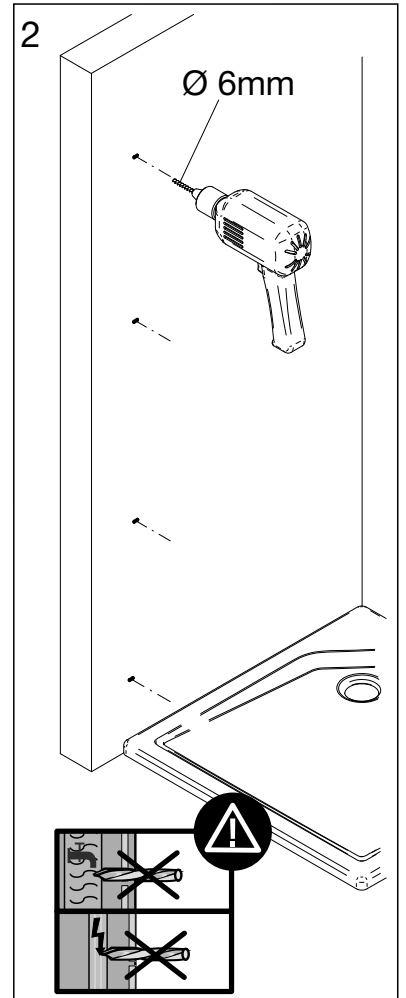

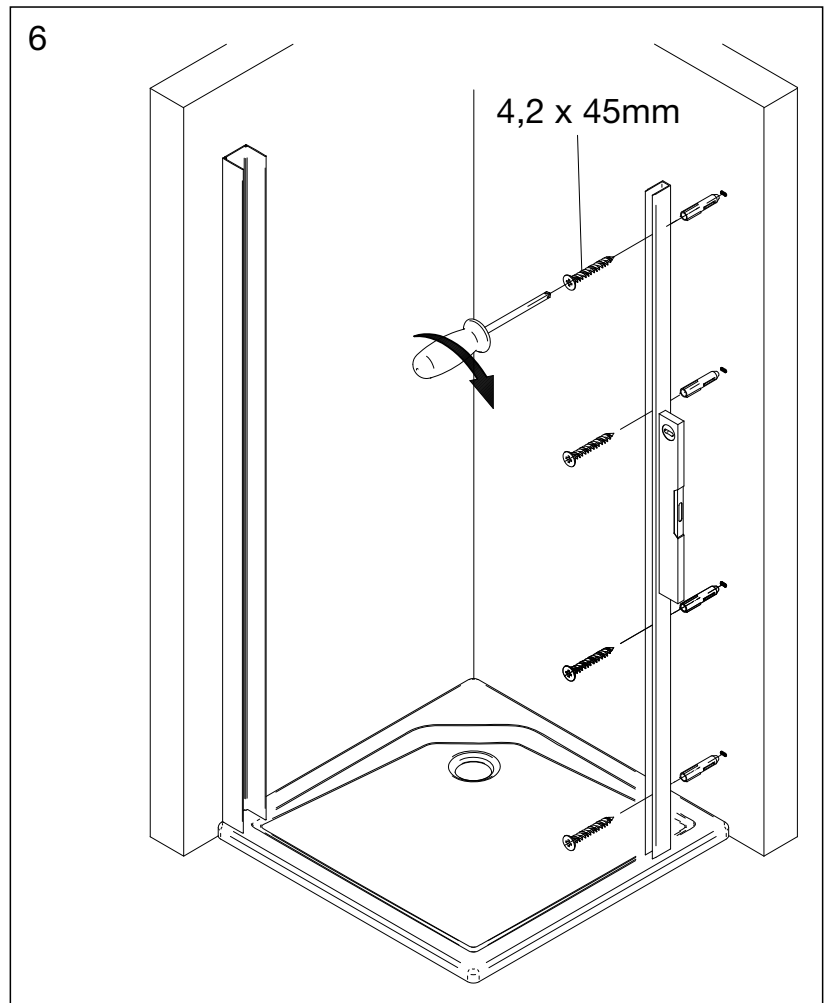
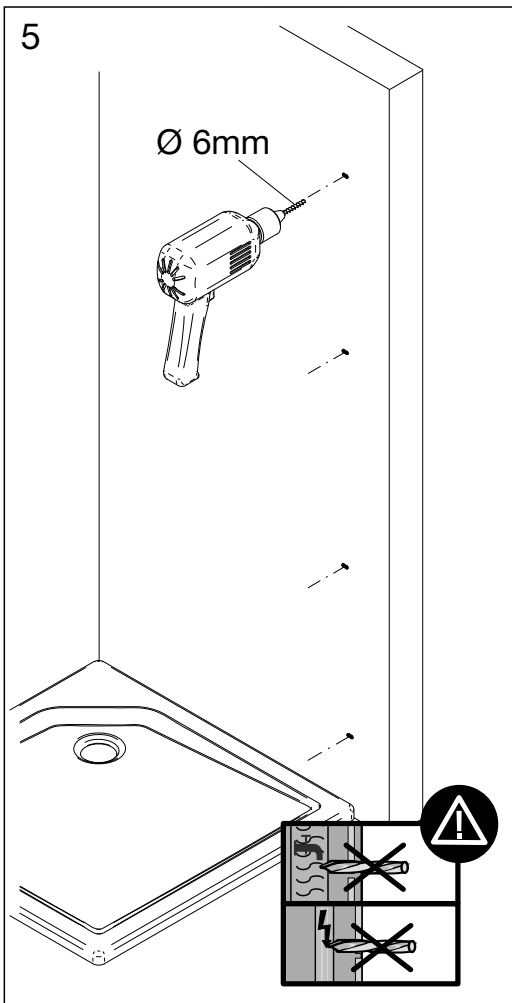
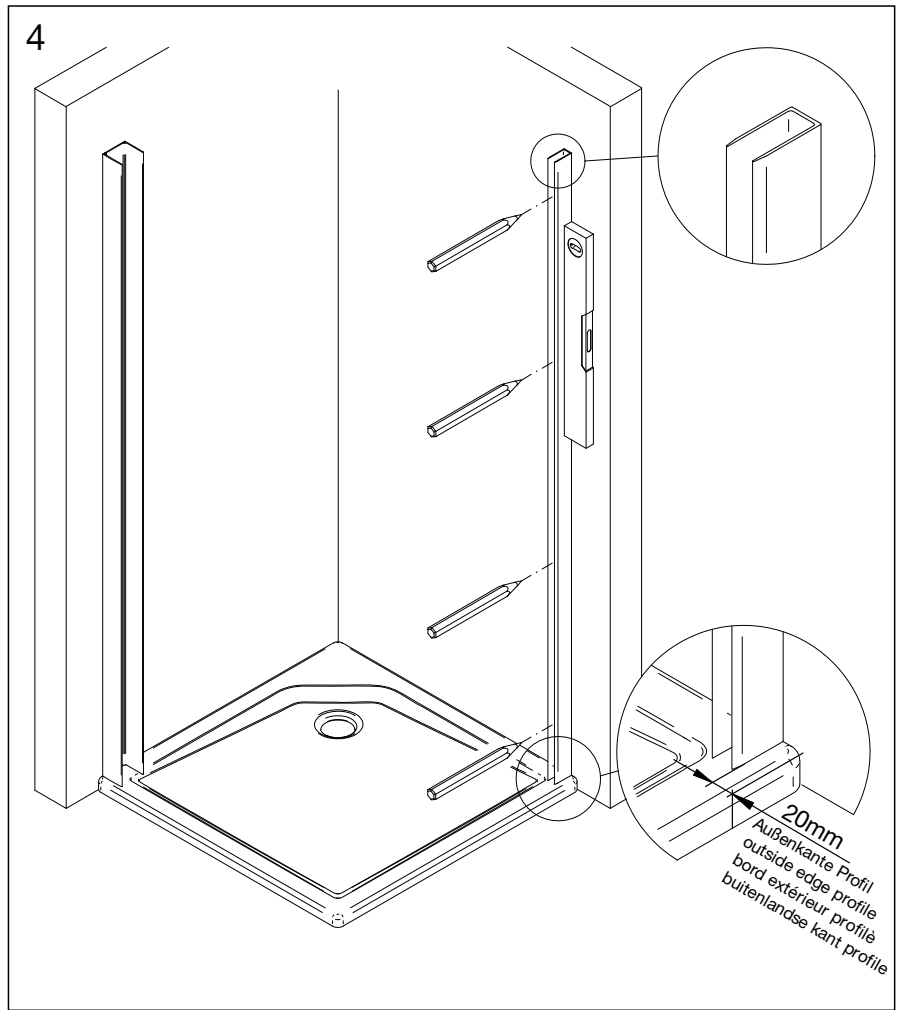
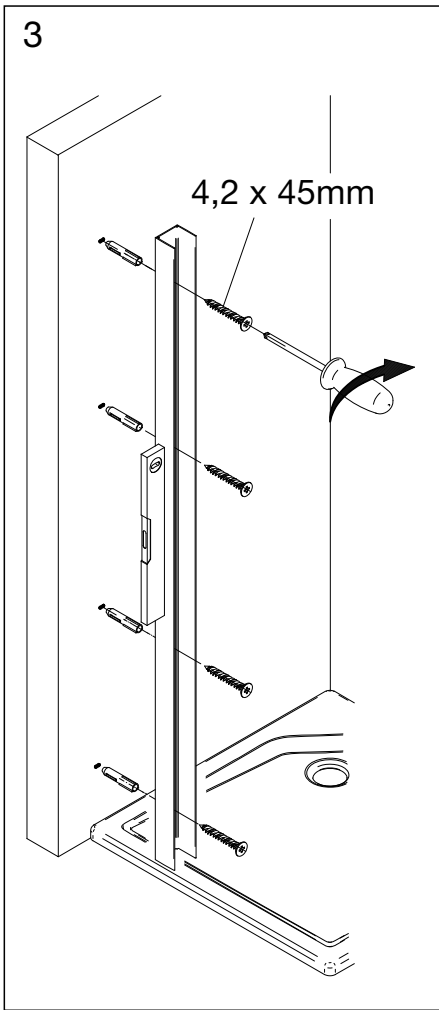

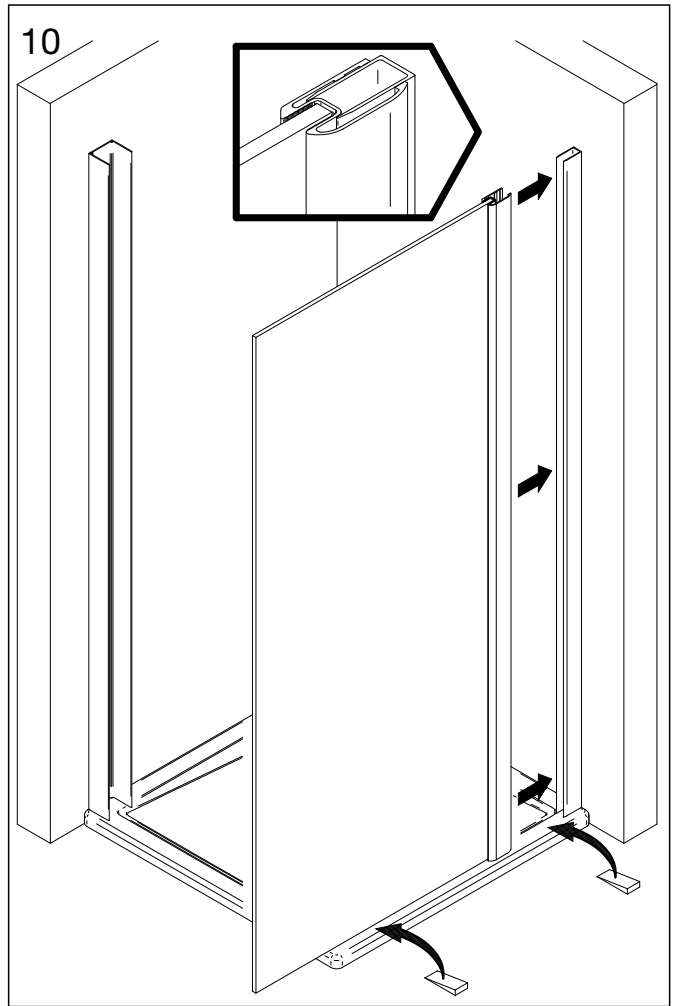
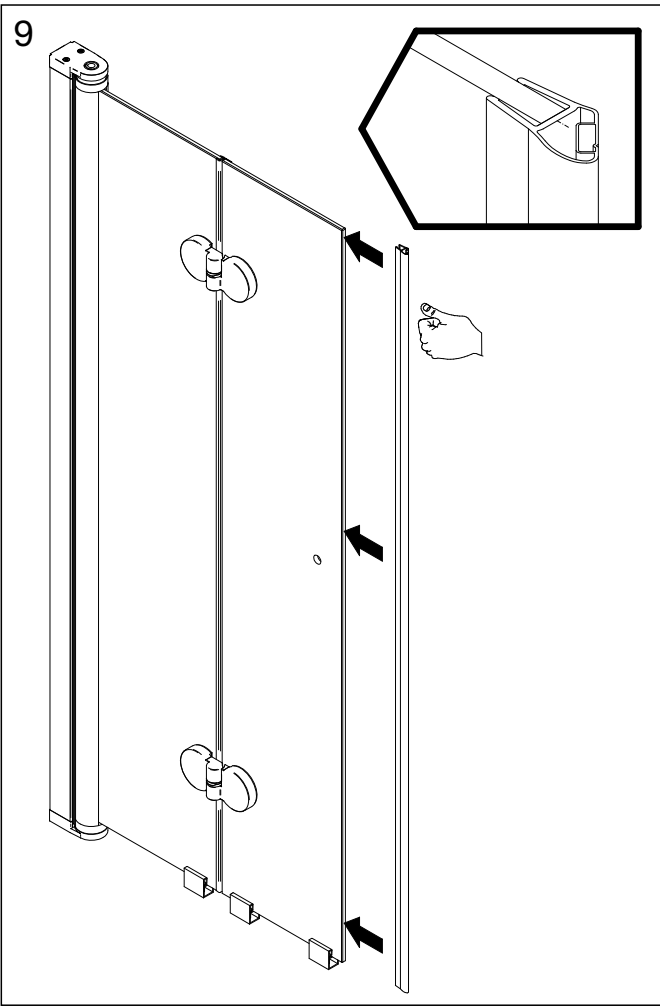
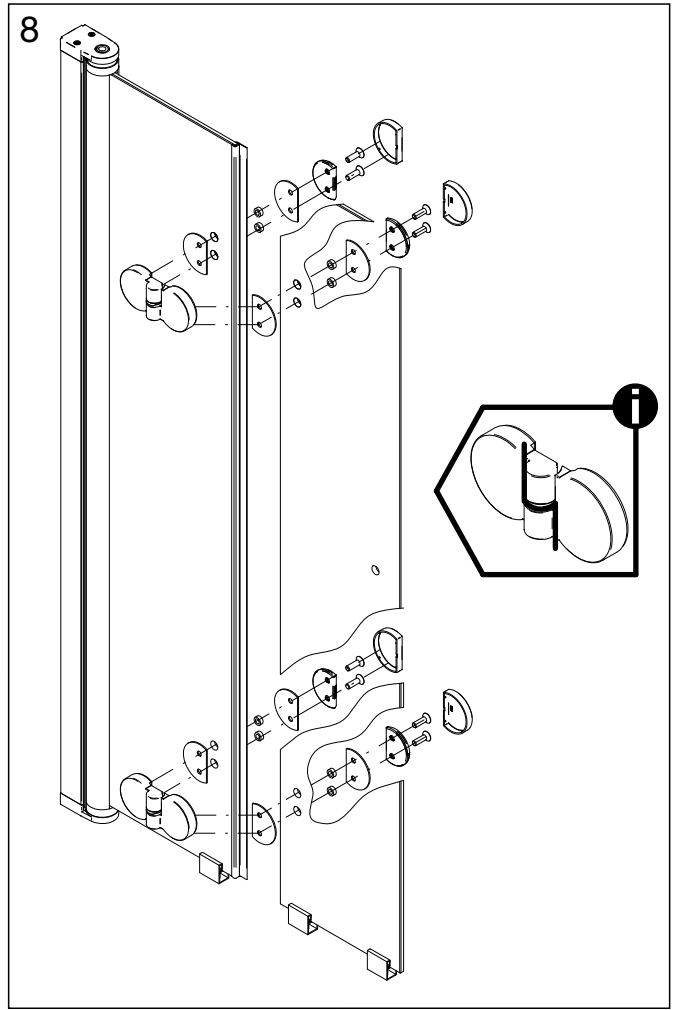
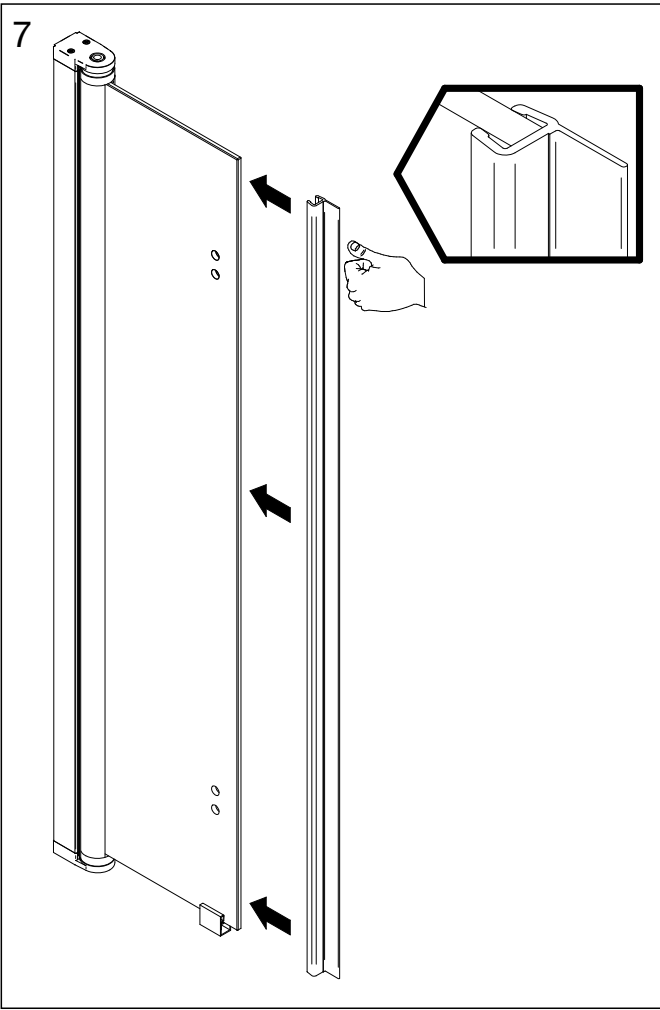

11

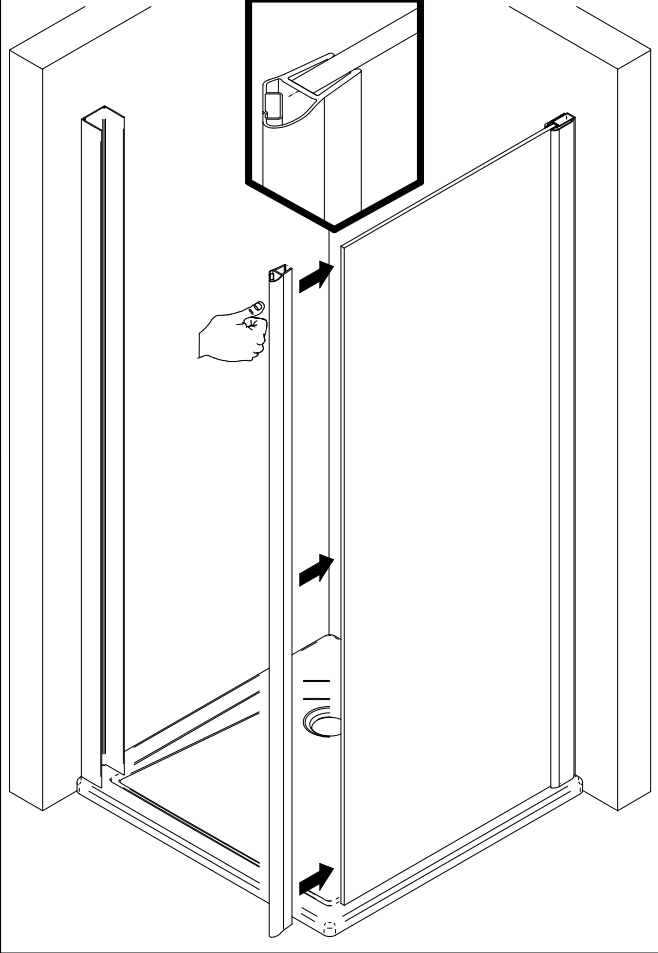

12

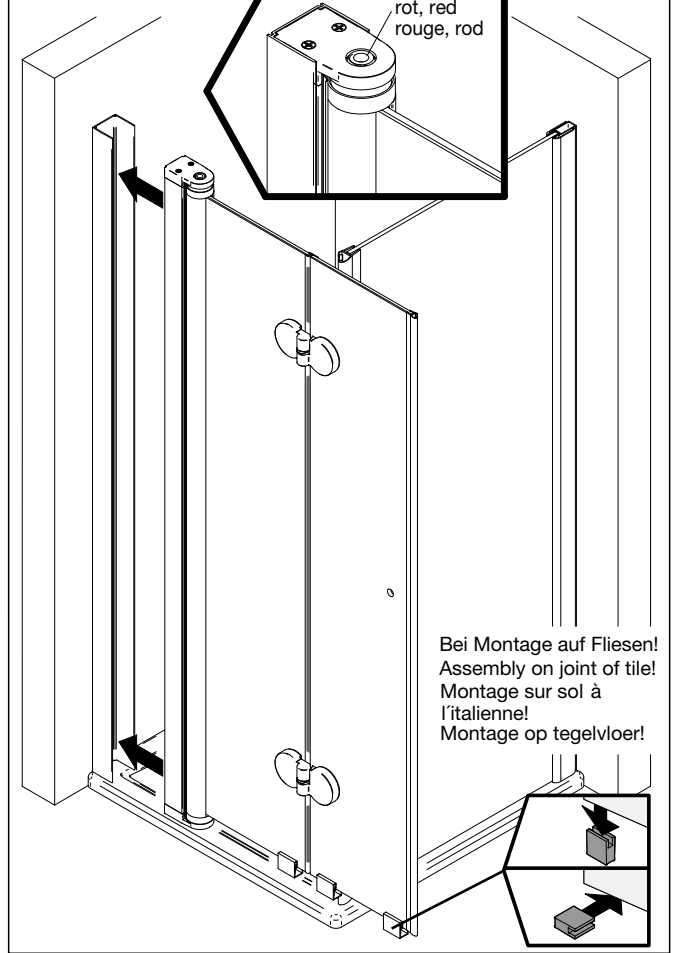

13

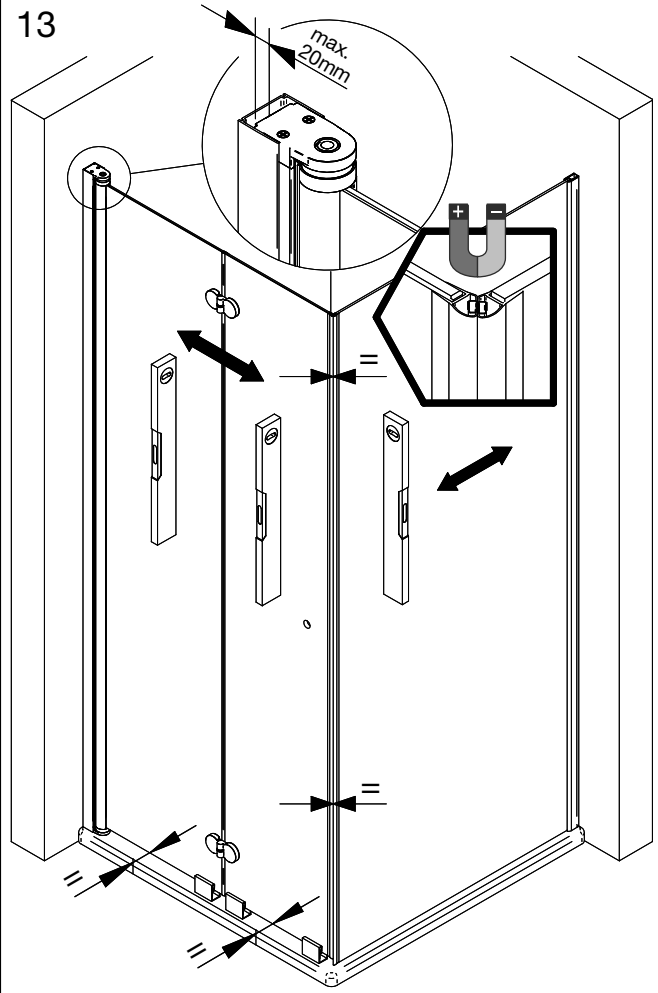

14

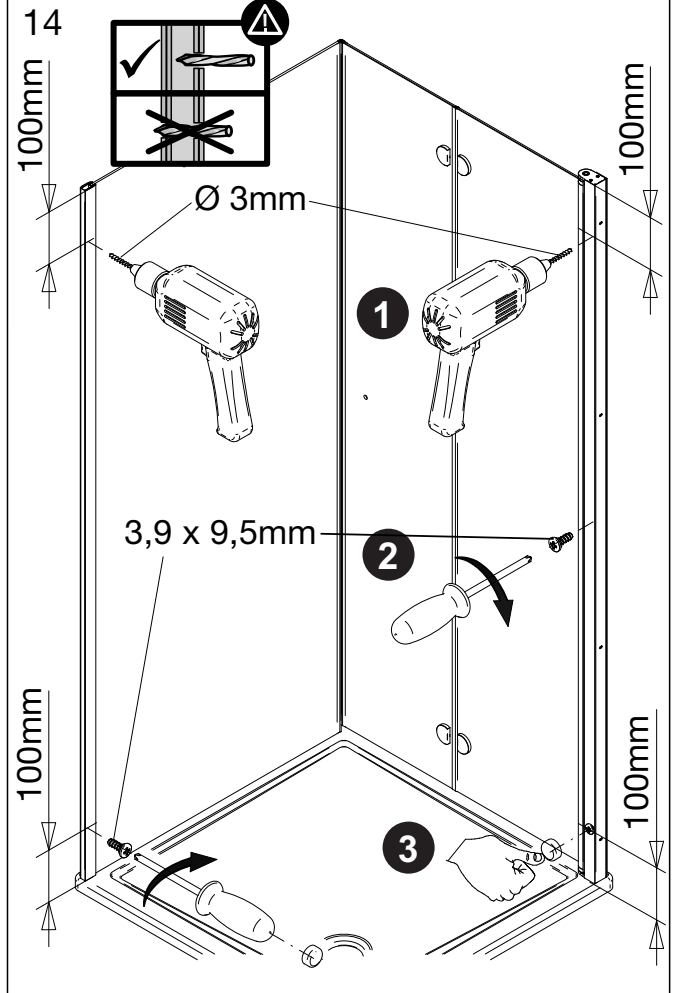

15

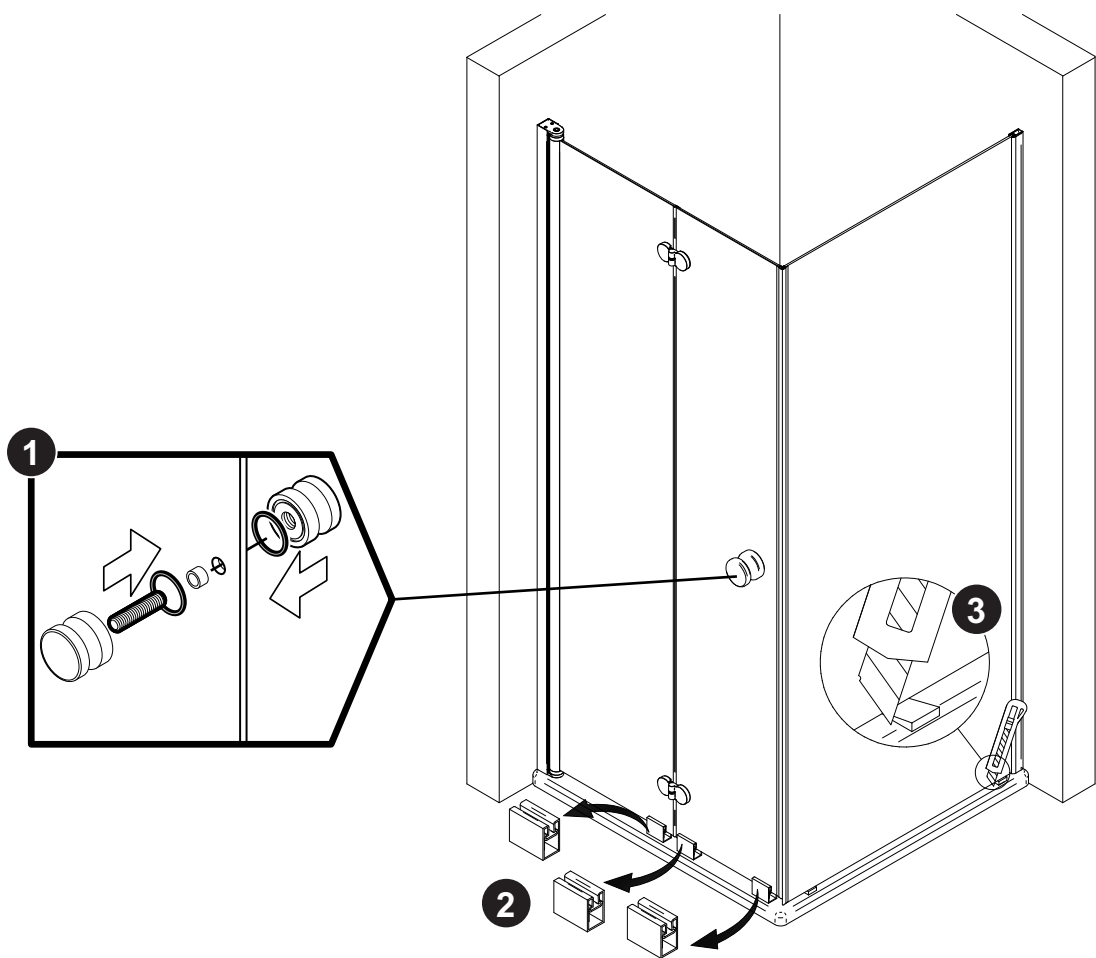

16

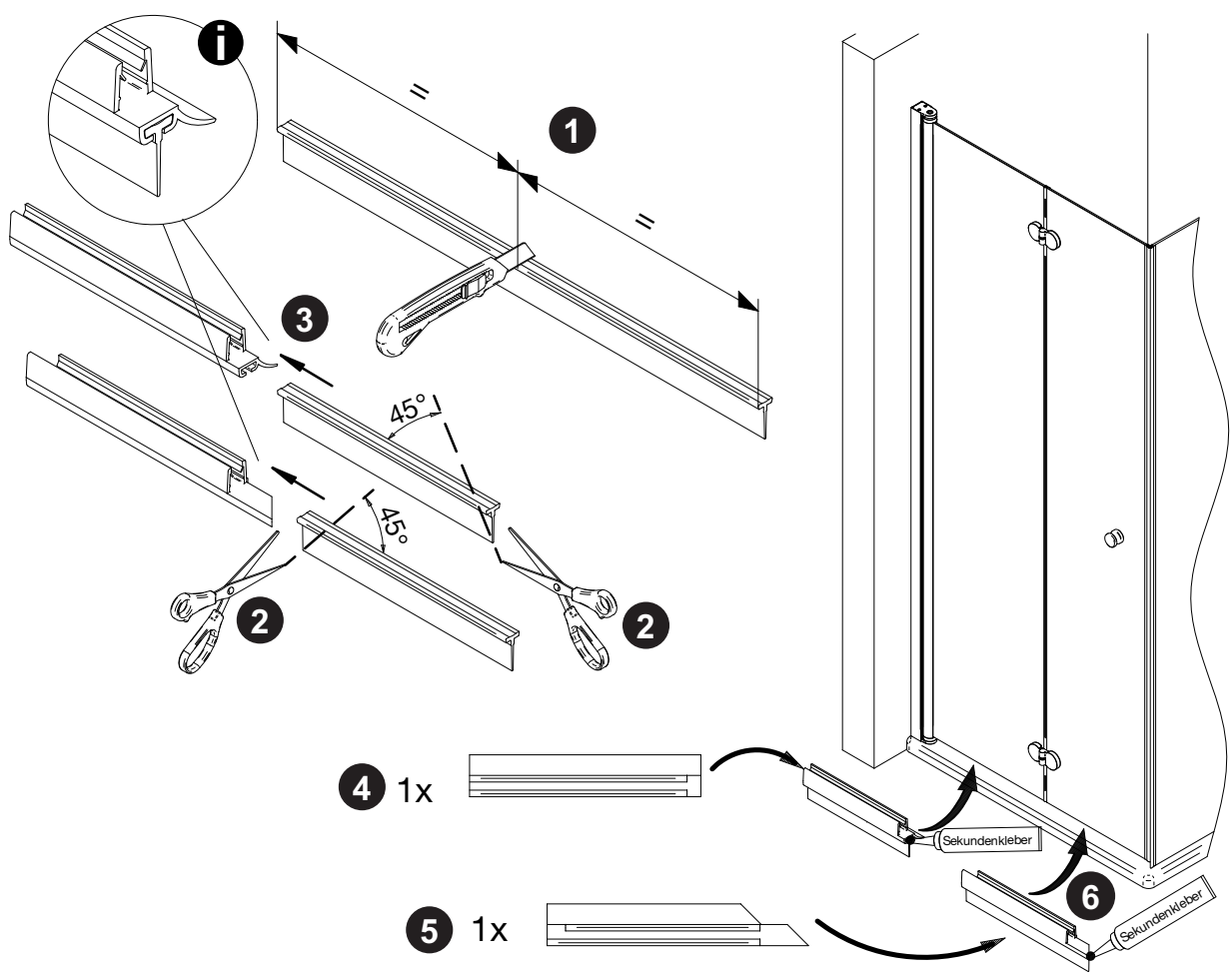

- 17 - Die Montage des Stabilisationsbügel entnehmen Sie dem Zusatzblatt.
- Please look into the additional sheet for the installation of the stabilizing bar.
 - Veuillez regarder dans la feuille additionnelle pour l'installation de la barre de stabilisation.
 - Voor de installatie van de stabilisatie stang zie aanvullende blad.

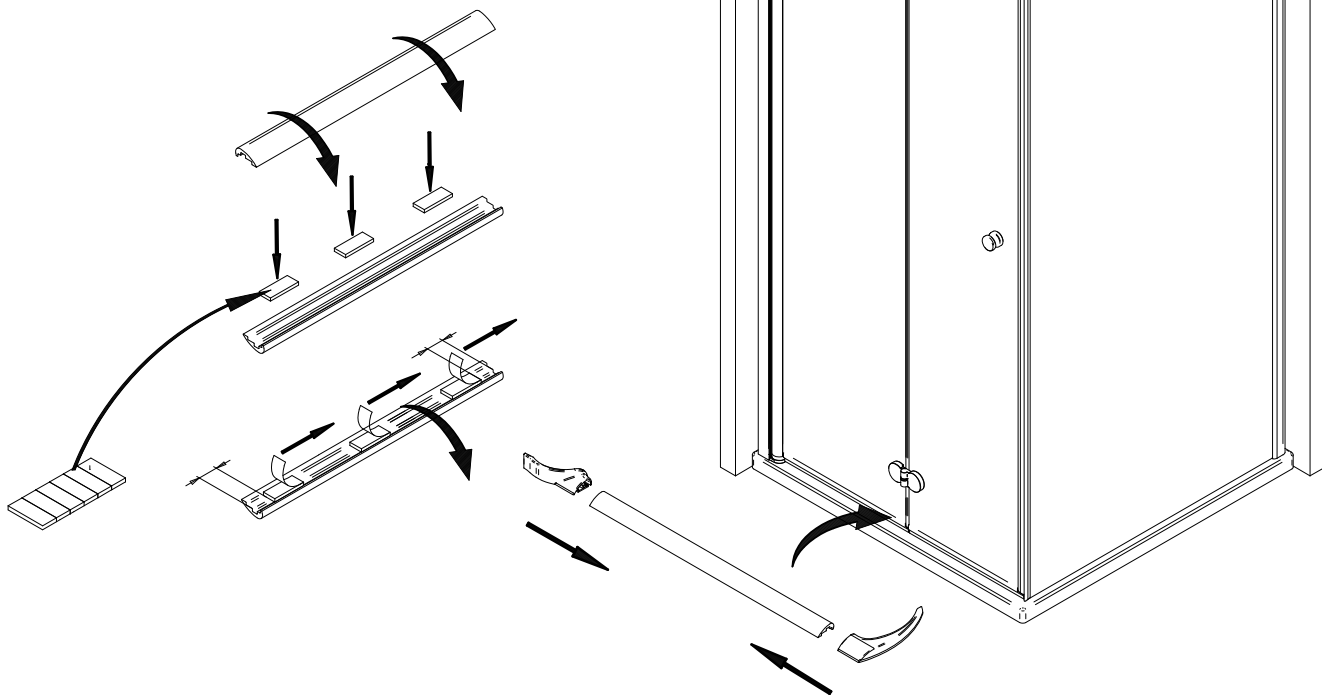

18

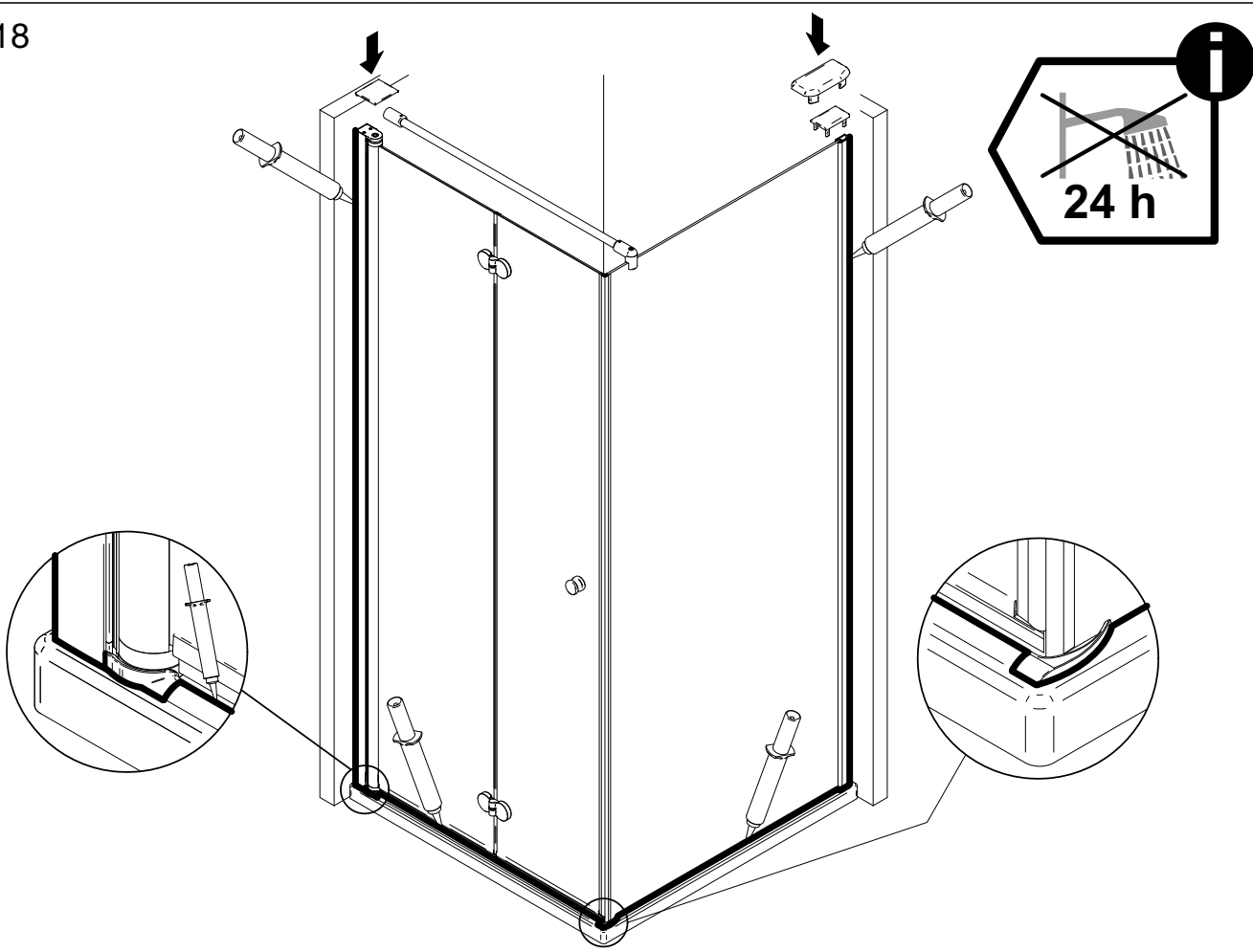

DFT + BSW

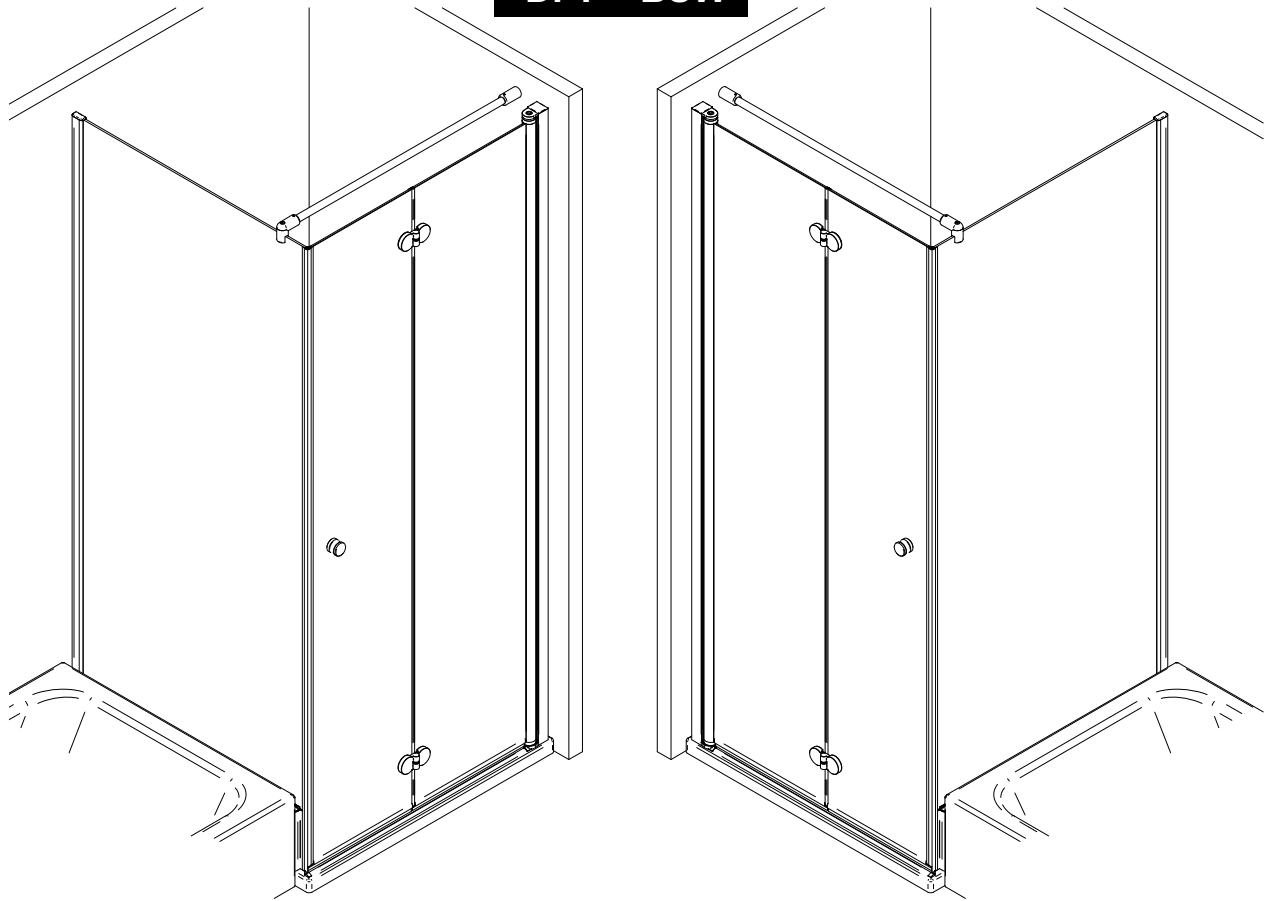

1

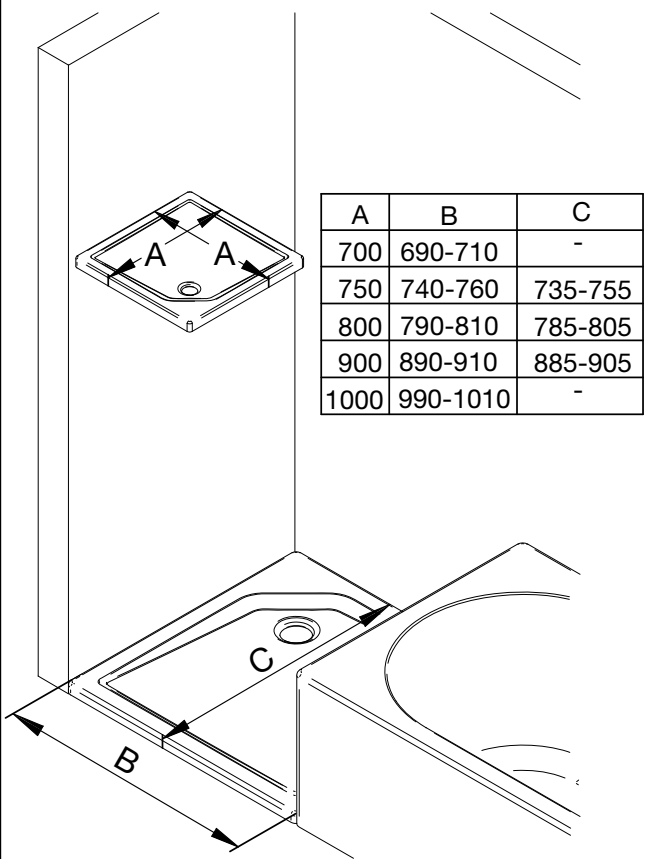

2

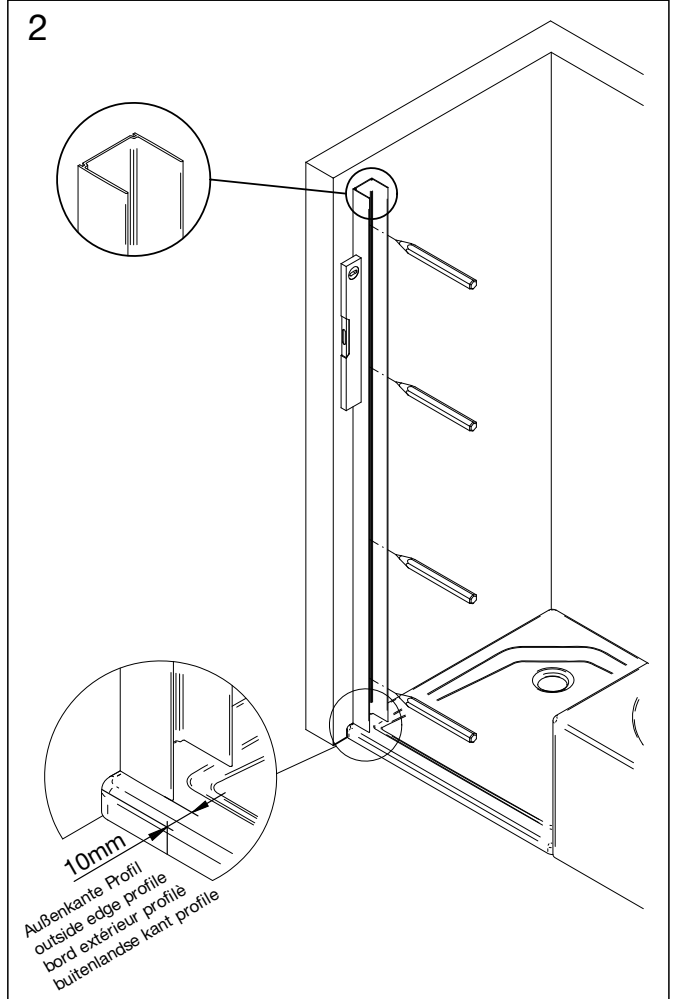

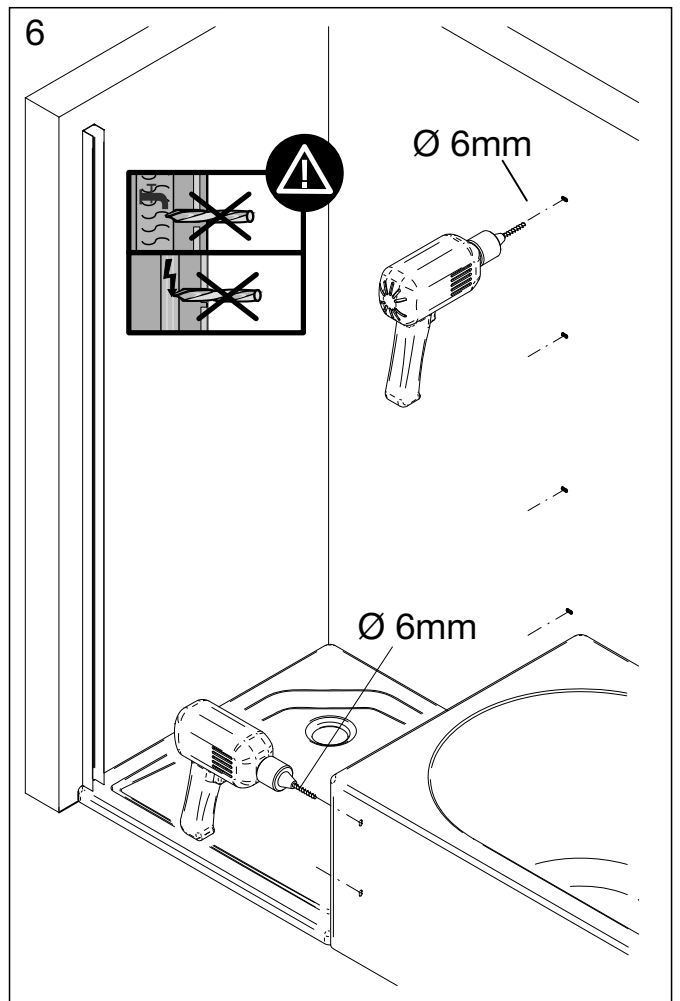
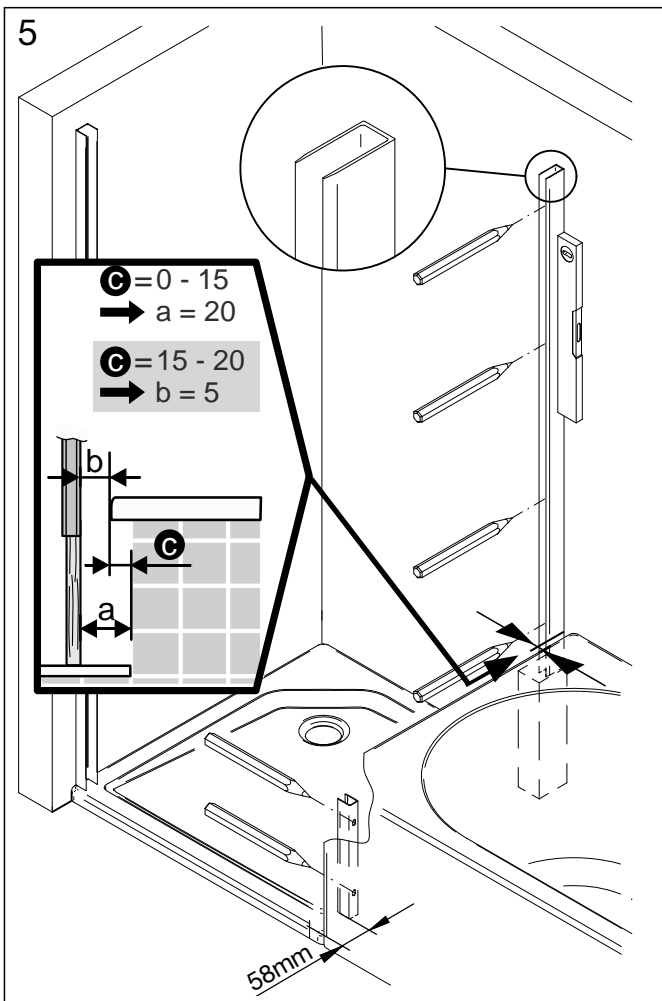
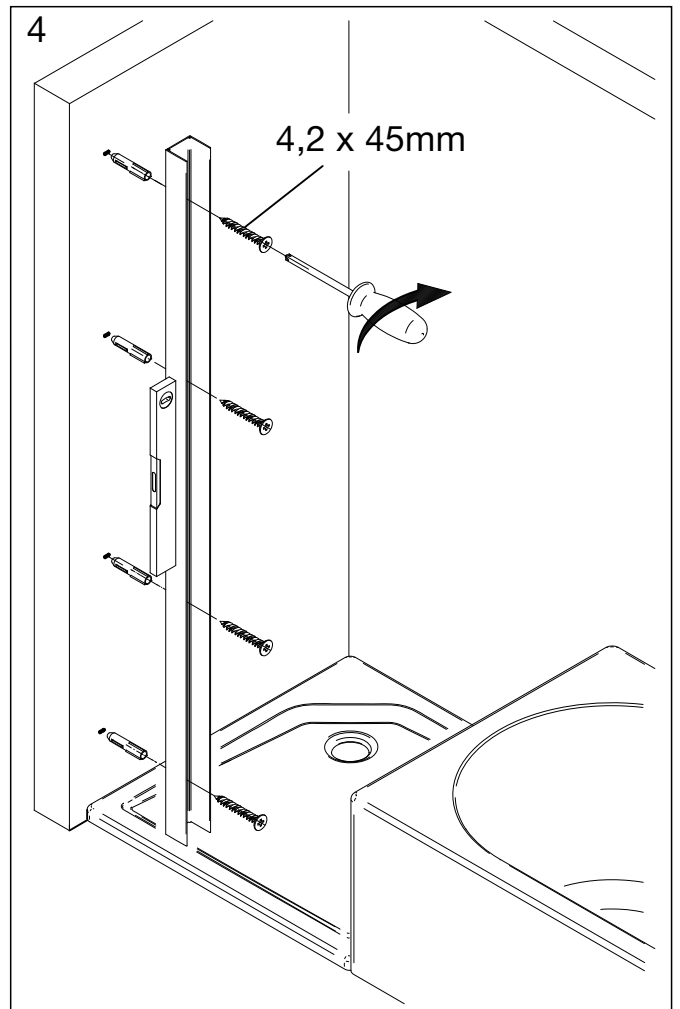
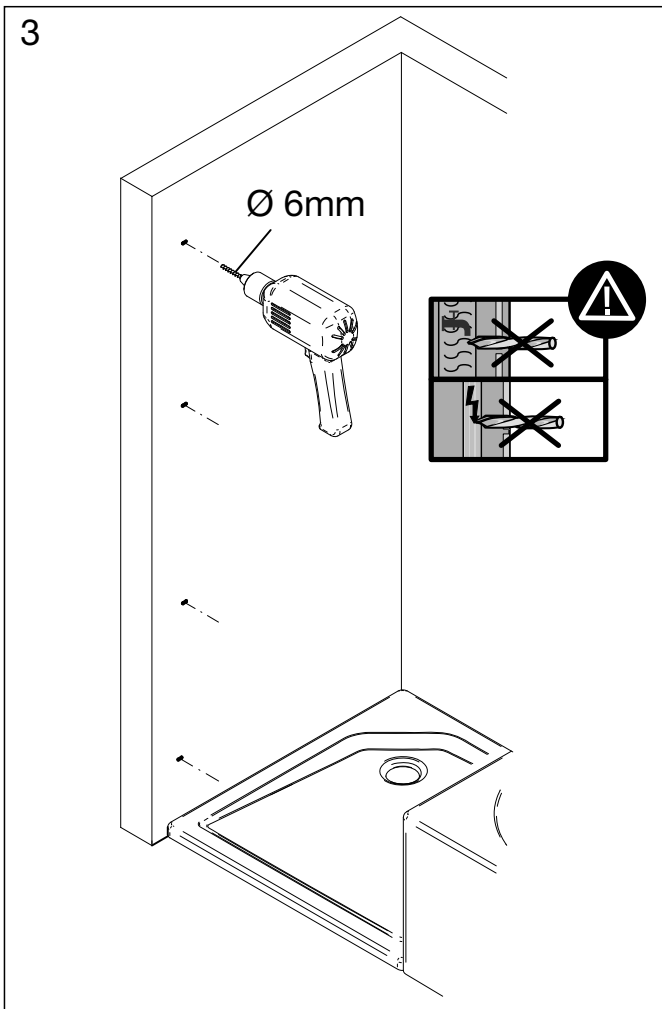

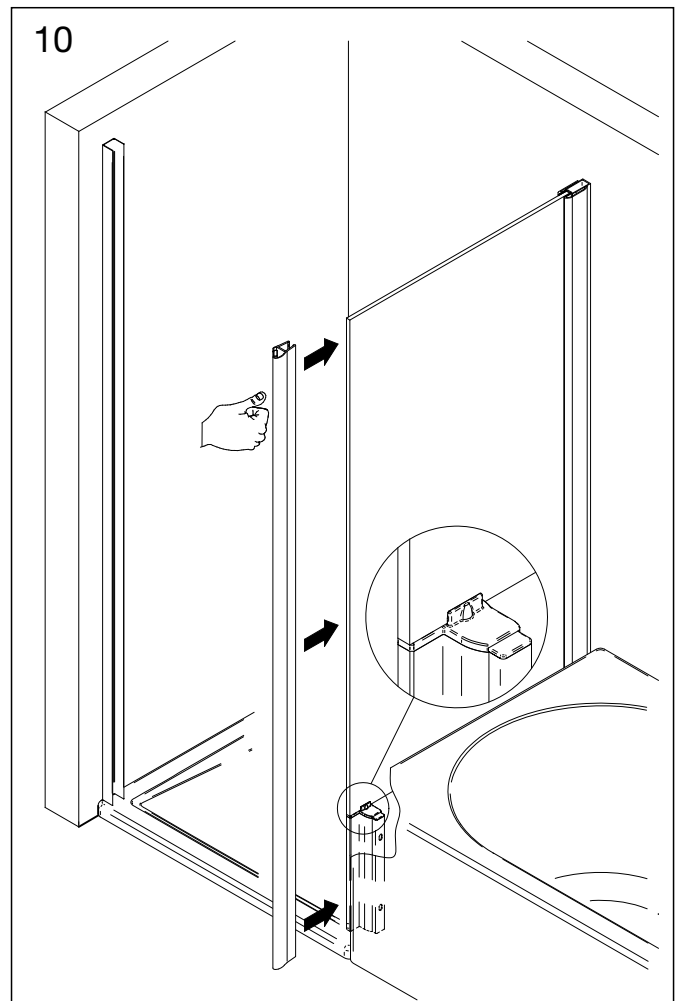
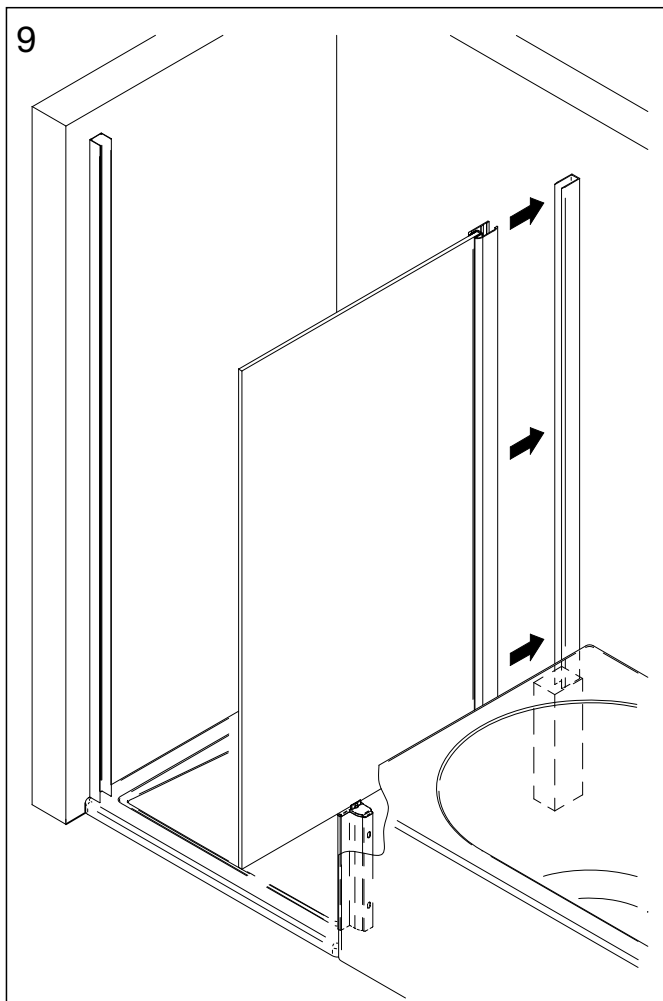
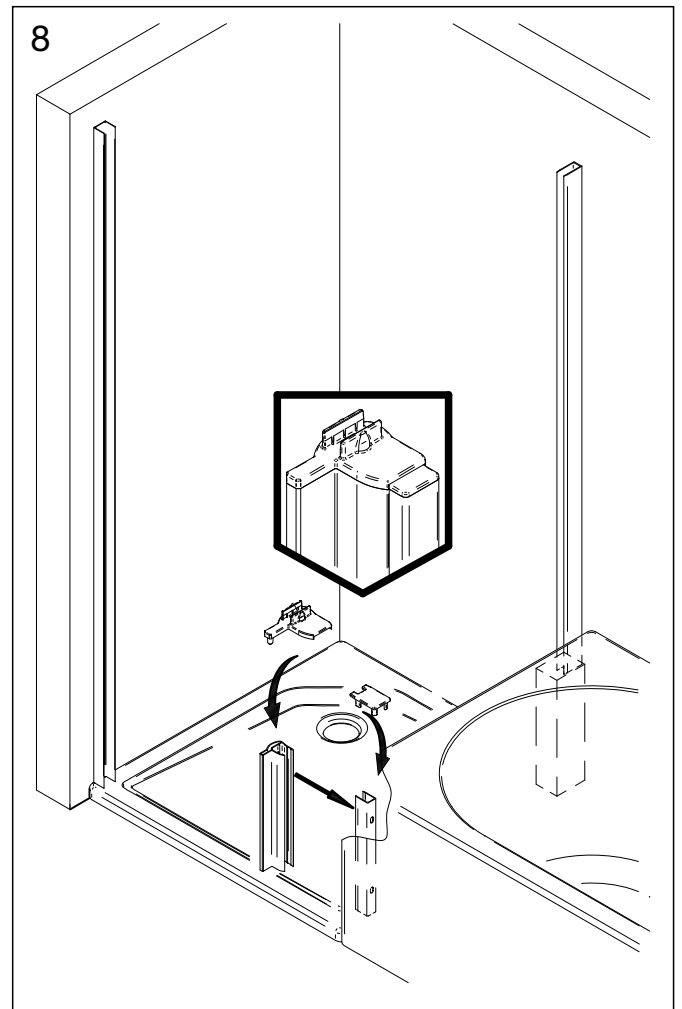
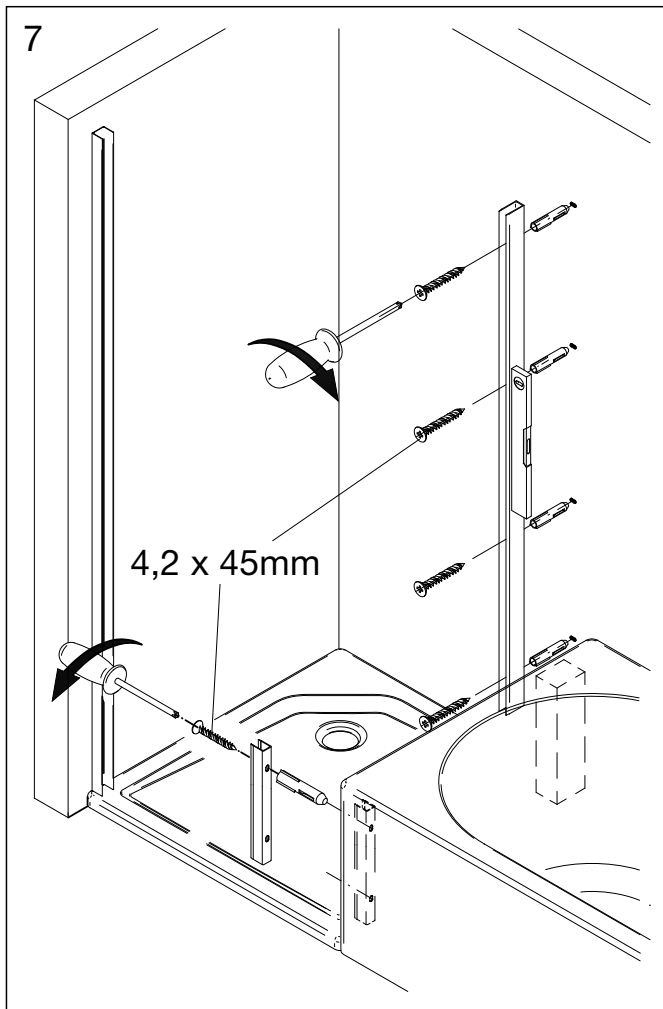

11

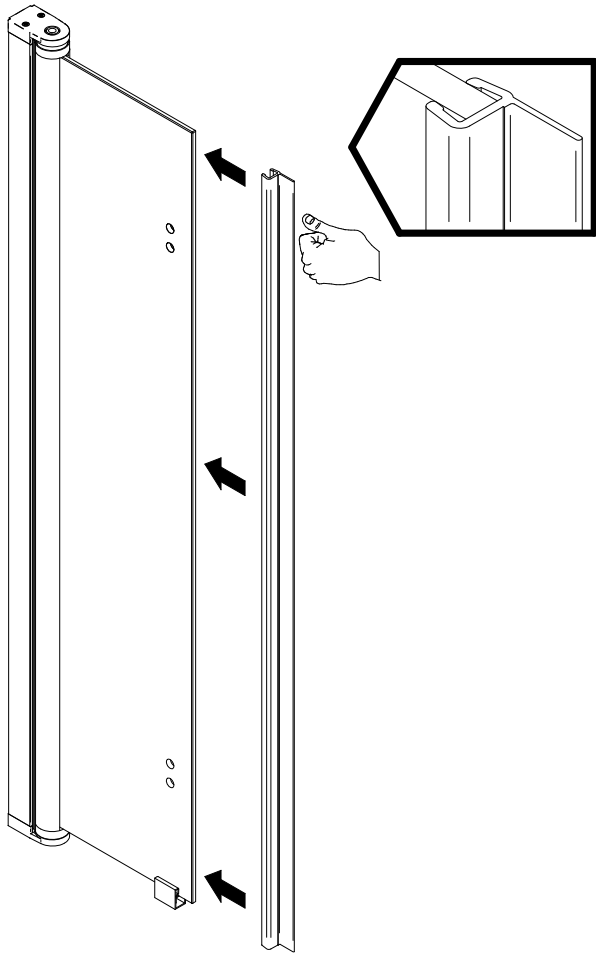

12

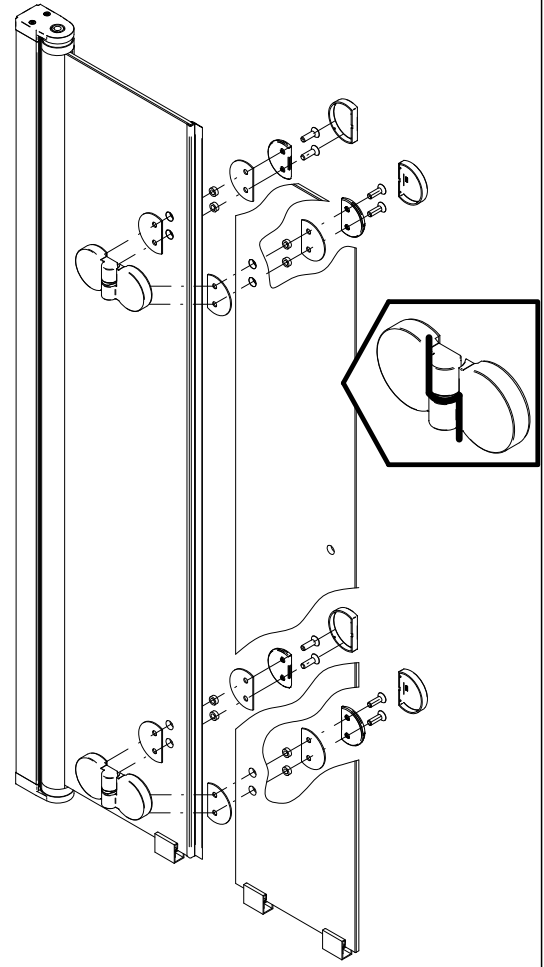

13

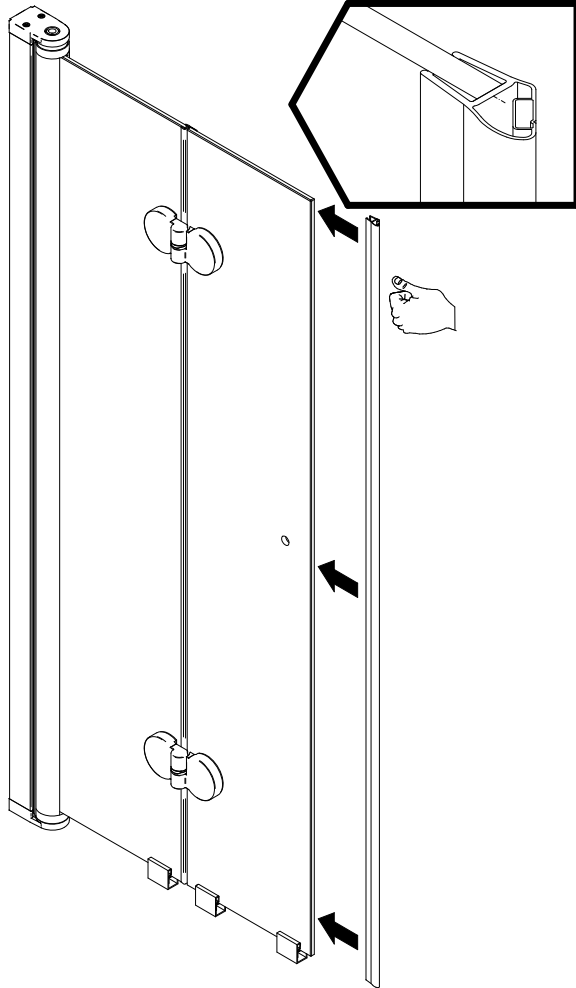

14

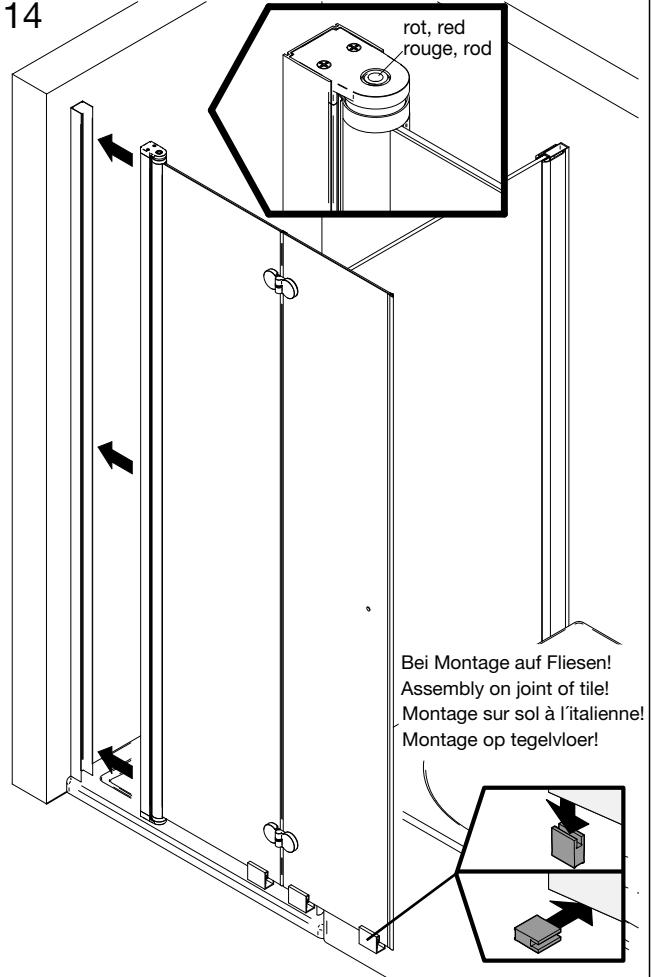

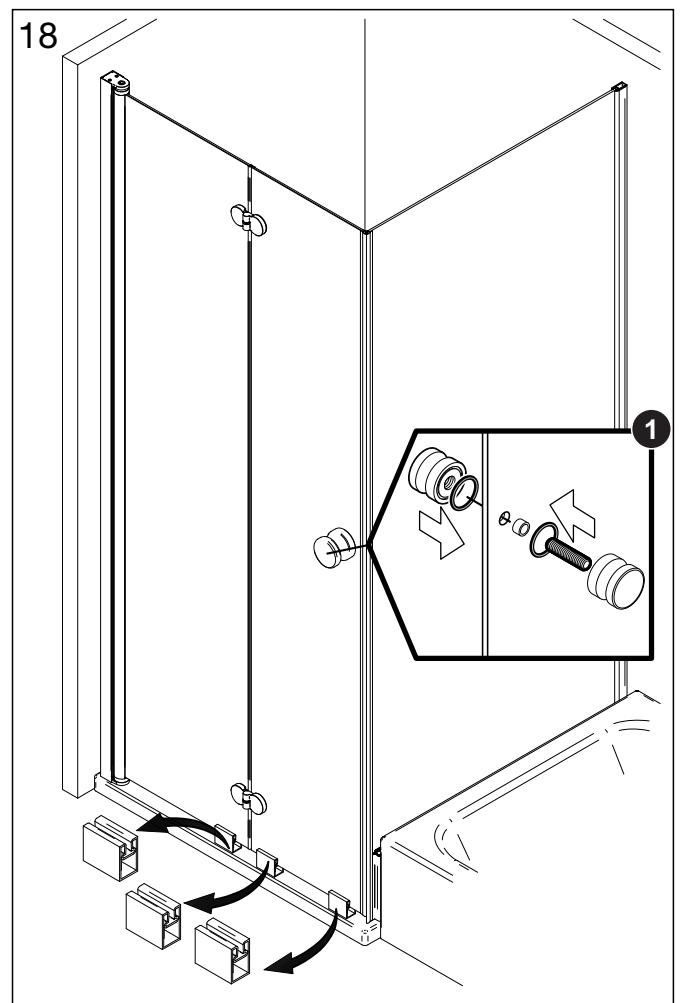
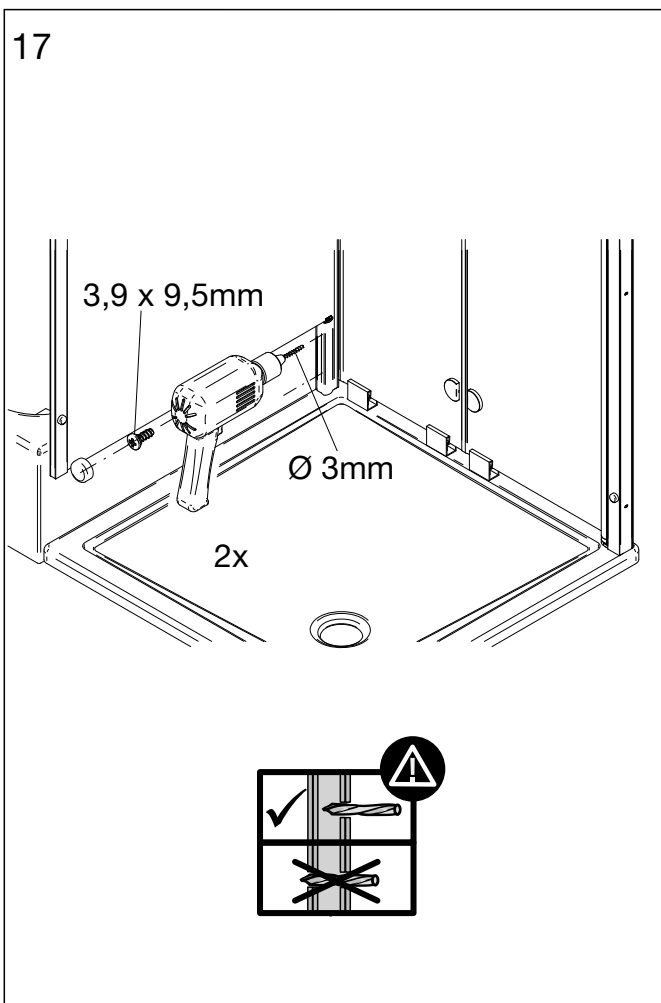
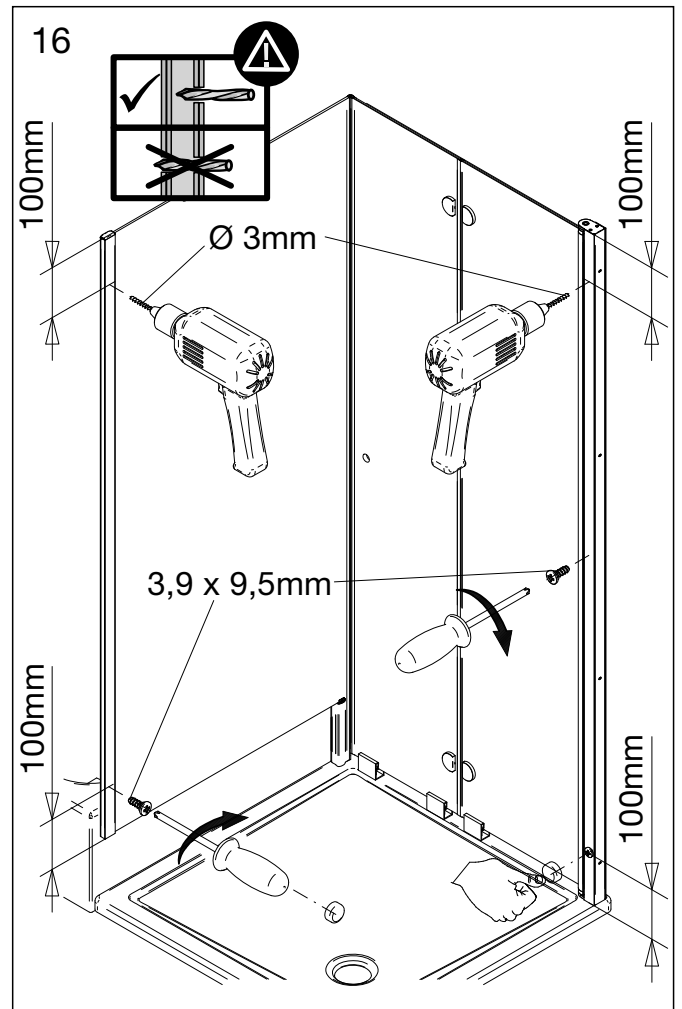
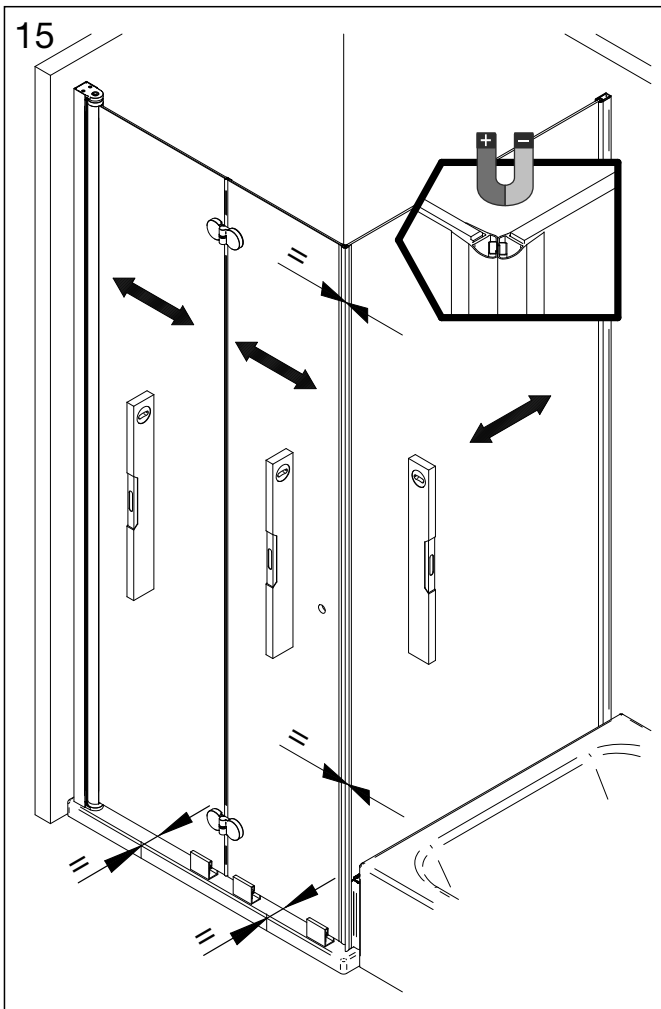

19

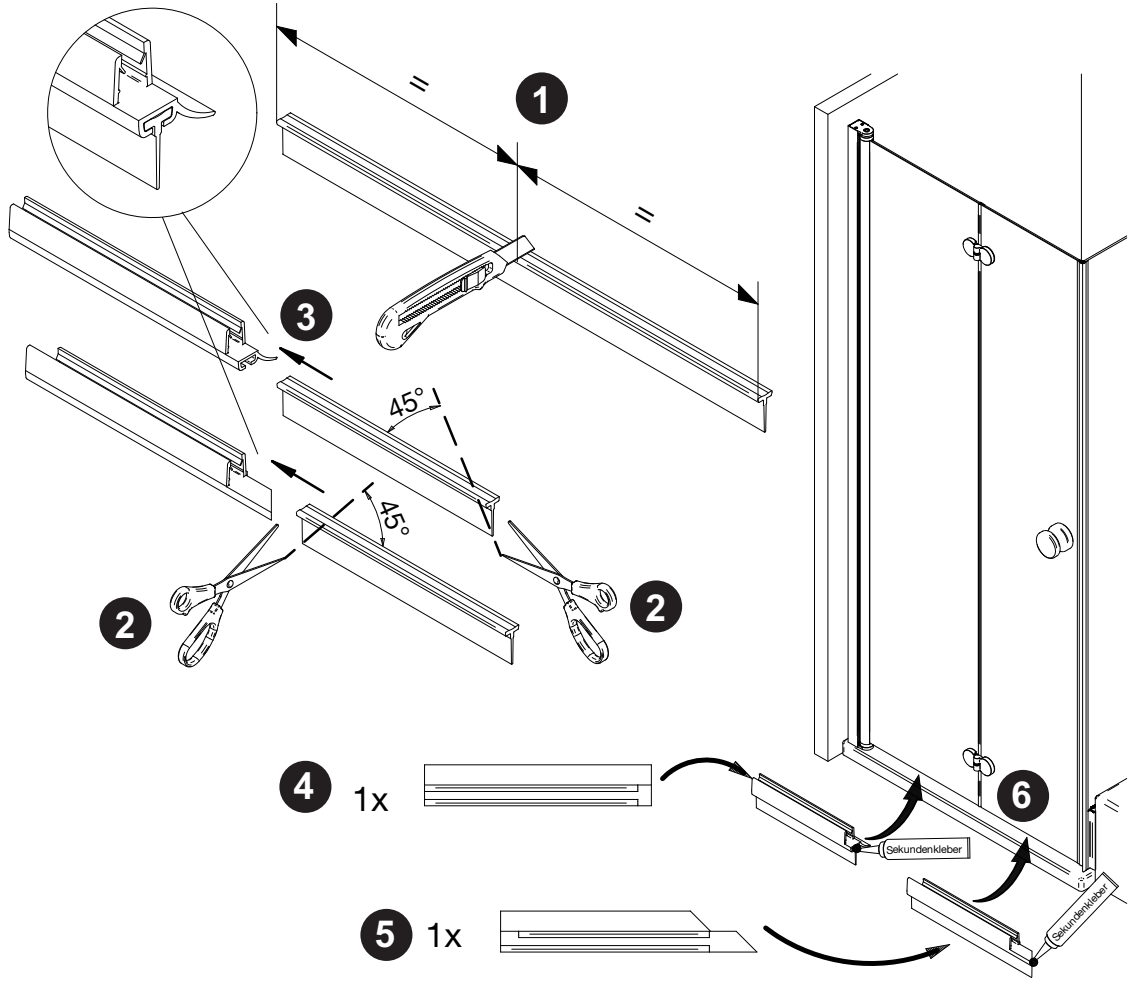

20

- Die Montage des Stabilisationsbügel entnehmen Sie dem Zusatzblatt.
- Please look into the additional sheet for the installation of the stabilizing bar.
- Veuillez regarder dans la feuille additionnelle pour l'installation de la barre de stabilisation.
- Voor de installatie van de stabilisatie stang zie aanvullende blad.

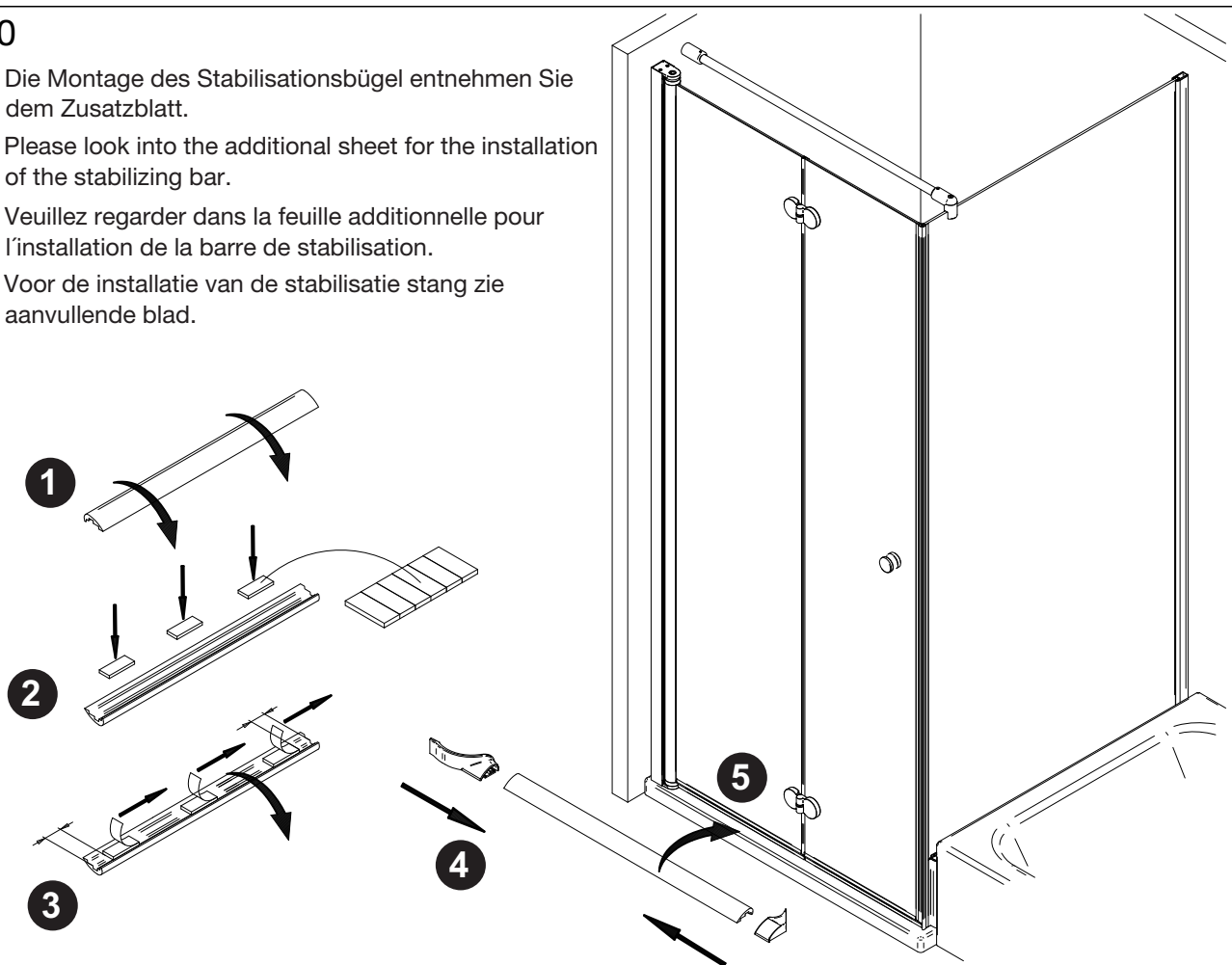

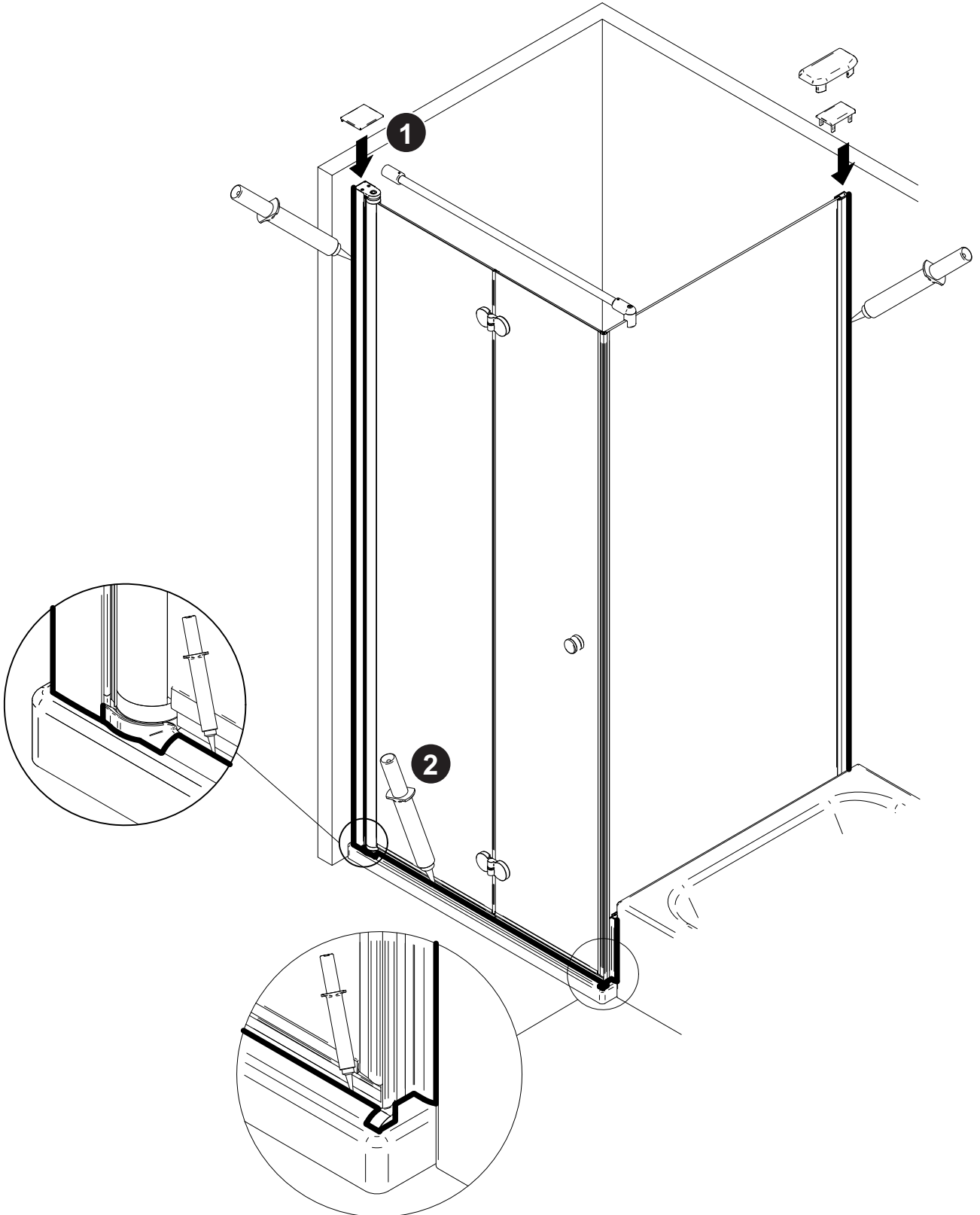
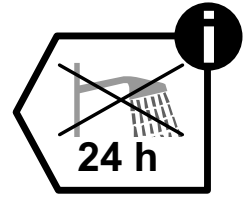

D Wichtiger Hinweis:
Duschkabinen bitte vor dem Einbau auf Transportschäden und Vollständigkeit prüfen, da Beanstandungen nach dem Aufbau nicht mehr anerkannt werden können.

GB Important information:
Please check the shower enclosure for transport damage and completeness before installation. Complaints made following installation cannot be accepted.

F Remarque importante:
avant de procéder au montage, vérifiez que le pare douche est complet et qu'il n'a pas été endommagé lors du transport. Aucune réclamation ne pourra être admise après le montage.

NL Belangrijk:
Controleer voor het inbouwen of het douchescherm bij het transport beschadigd is en of het volledig is. Na het inbouwen kunnen klachten niet meer in behandeling genomen worden.

D Sicherheitshinweis:
Einscheiben-Sicherheitsgläser nie nachträglich bearbeiten.

GB Safety information:
Single pane, safety glass panels must not be reworked in any way following supply.

F Remarques concernant la sécurité:
Vous ne devez en aucune façon tenter de retailler les vitrages en verre sécurité.

NL Veiligheidsvoorschrift:
Gehard veiligheidsglas mag niet achteraf worden bewerkt.

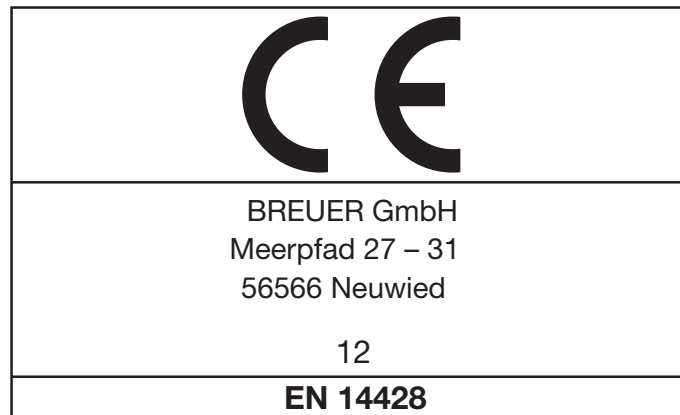

D	Duschabtrennung aus einem bestimmten Scheibenmaterial
Reinigbarkeit:	Bestanden
Brucheigenschaften:	Bestanden
Dauerhaftigkeit:	Bestanden

F	Paroi de douche dans un matériau vitré particulier
Nettoyabilité:	passé avec succès
Propriétés à la cassure:	passé avec succès
Durabilité:	passé avec succès

GB	Shower enclosure made of a specific plane material
Cleanability:	Passed
Fracture behaviour:	Passed
Durability:	Passed

NL	Douche-afscheiding van bepaald ruitmateriaal
Reinigbaarheid:	Doorstaan
Bruekeigenschappen:	Doorstaan
Duurzaamheid:	Doorstaan