

N2 ESR/L

A

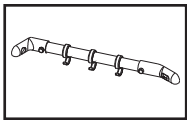

N2 TWD

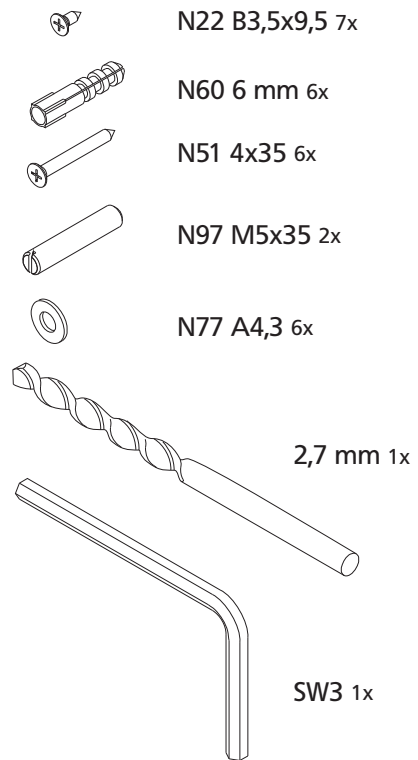
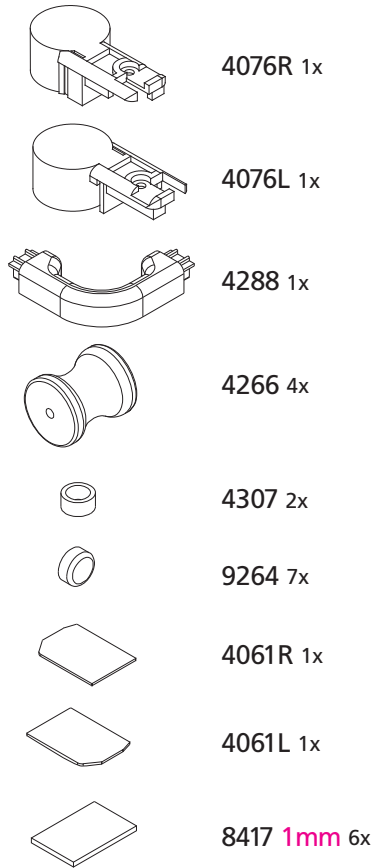
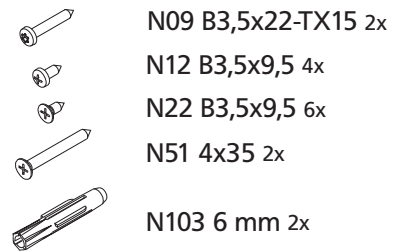
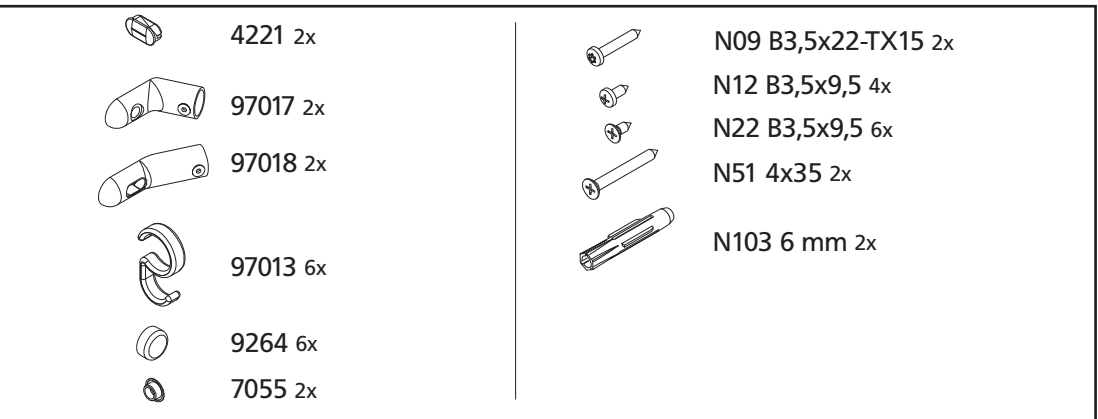

B

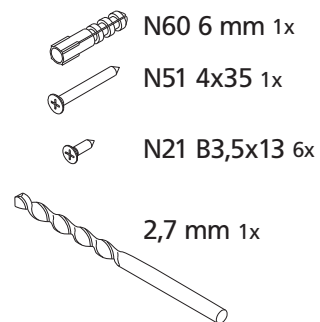
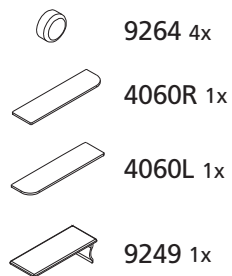

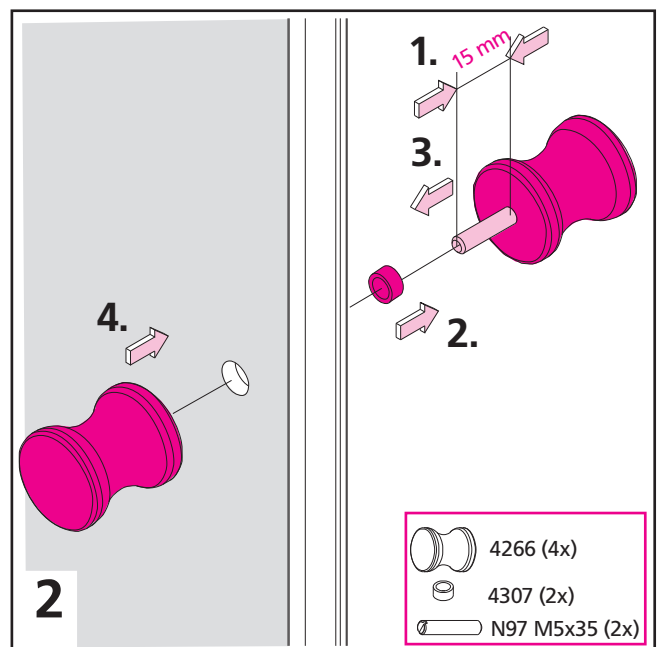
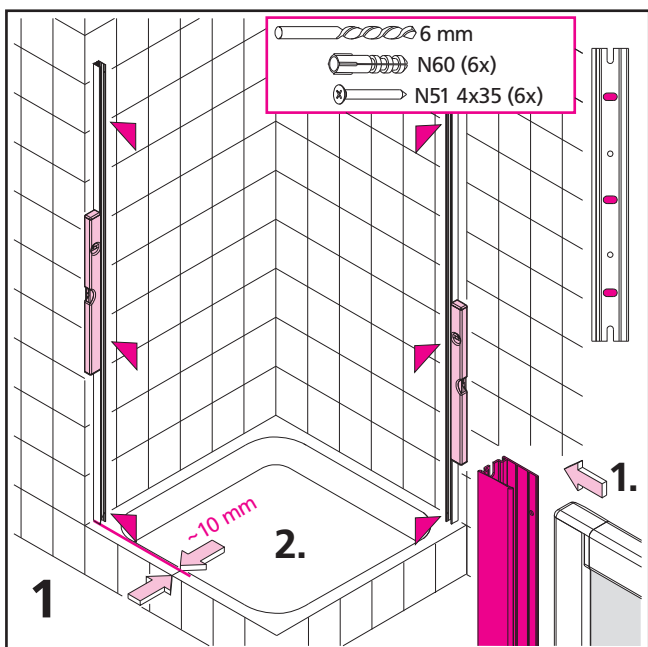
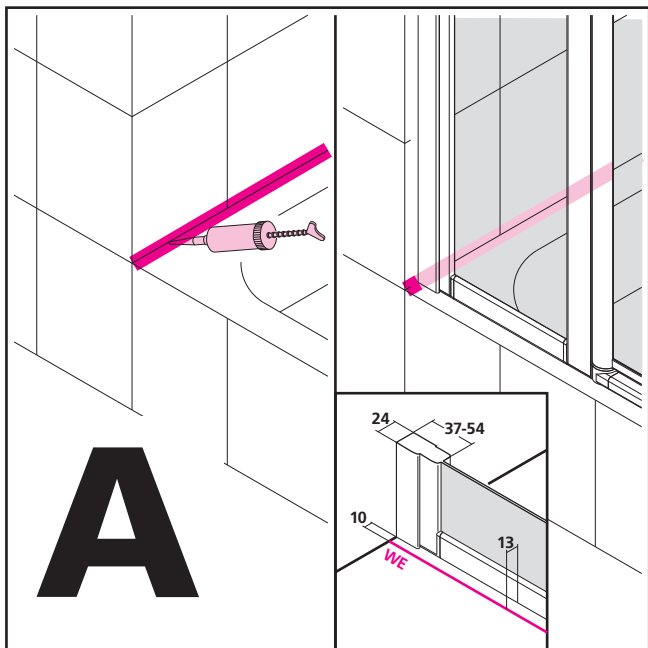
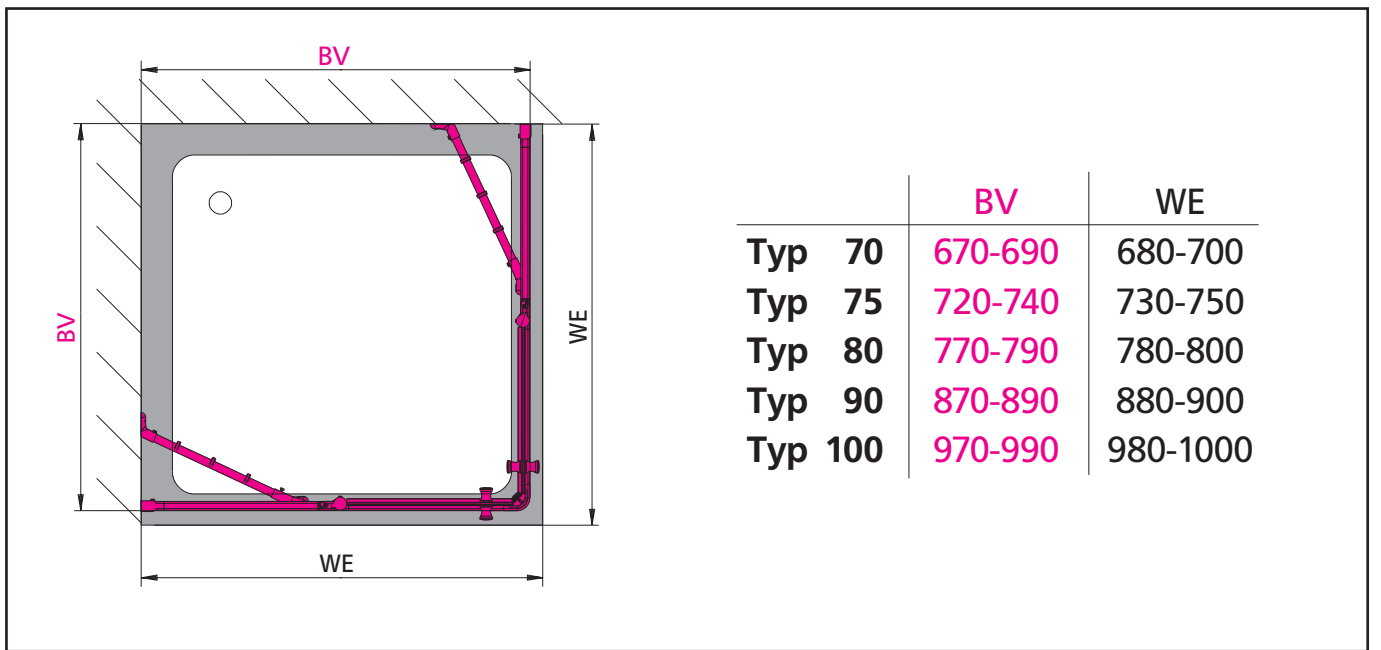

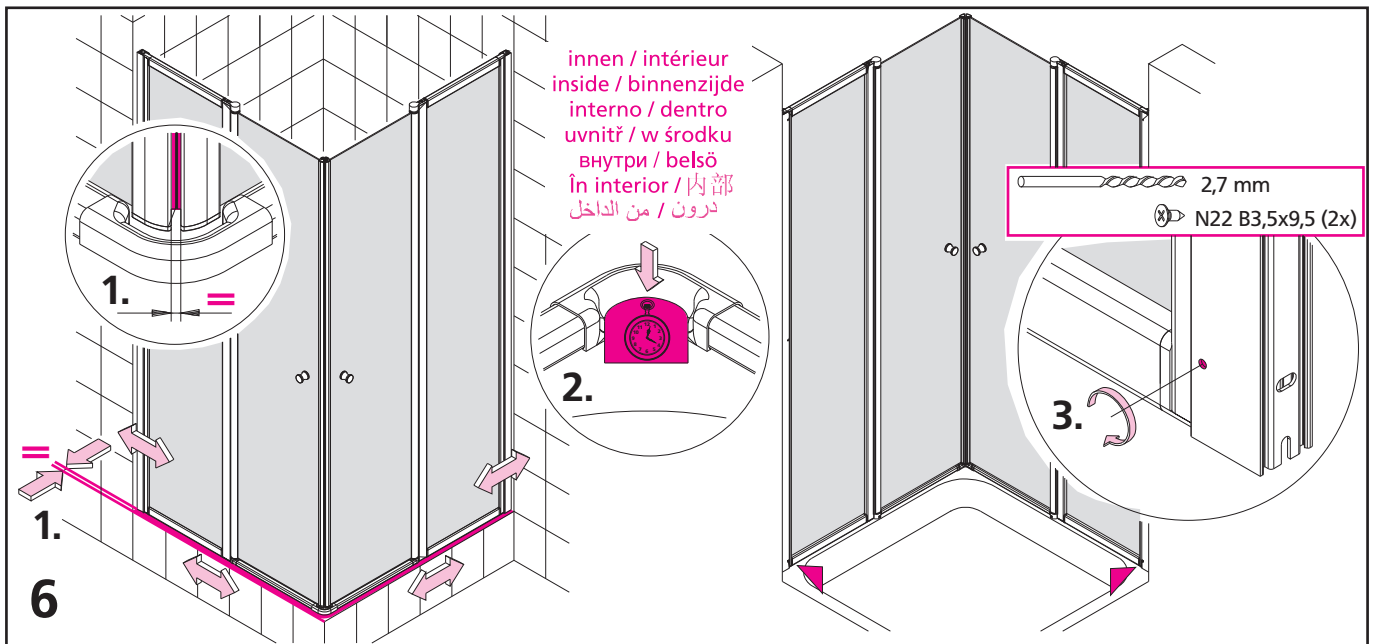
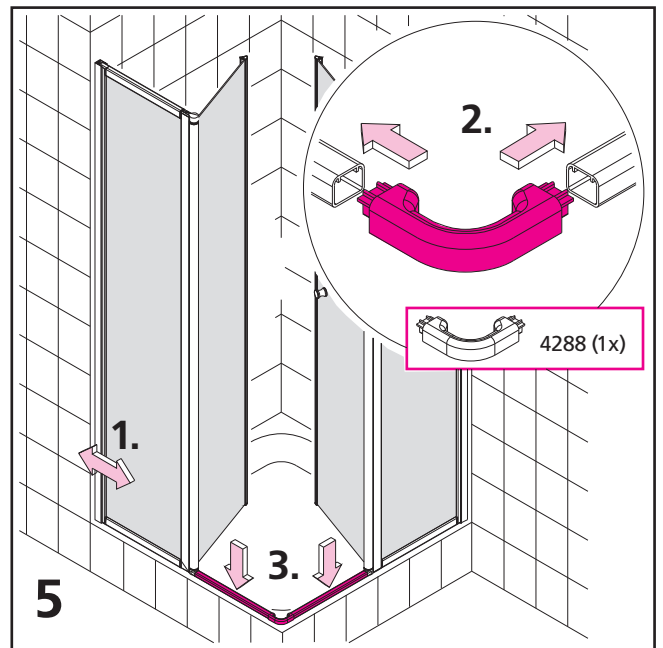
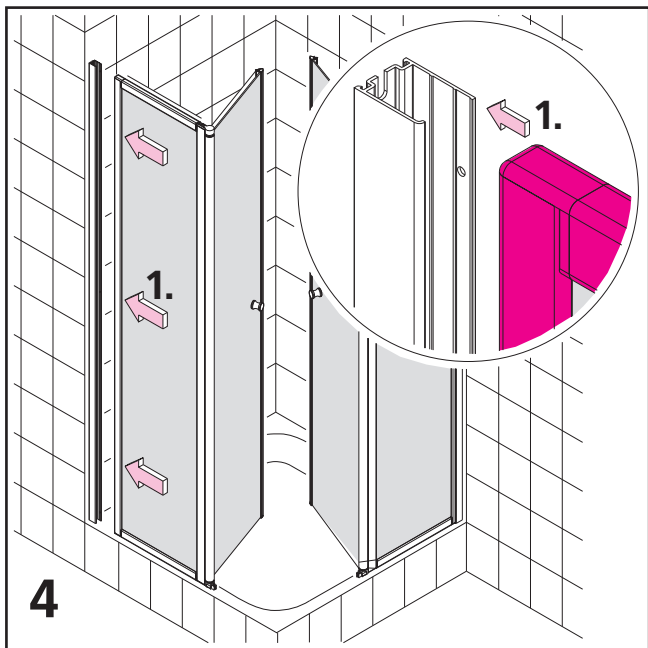
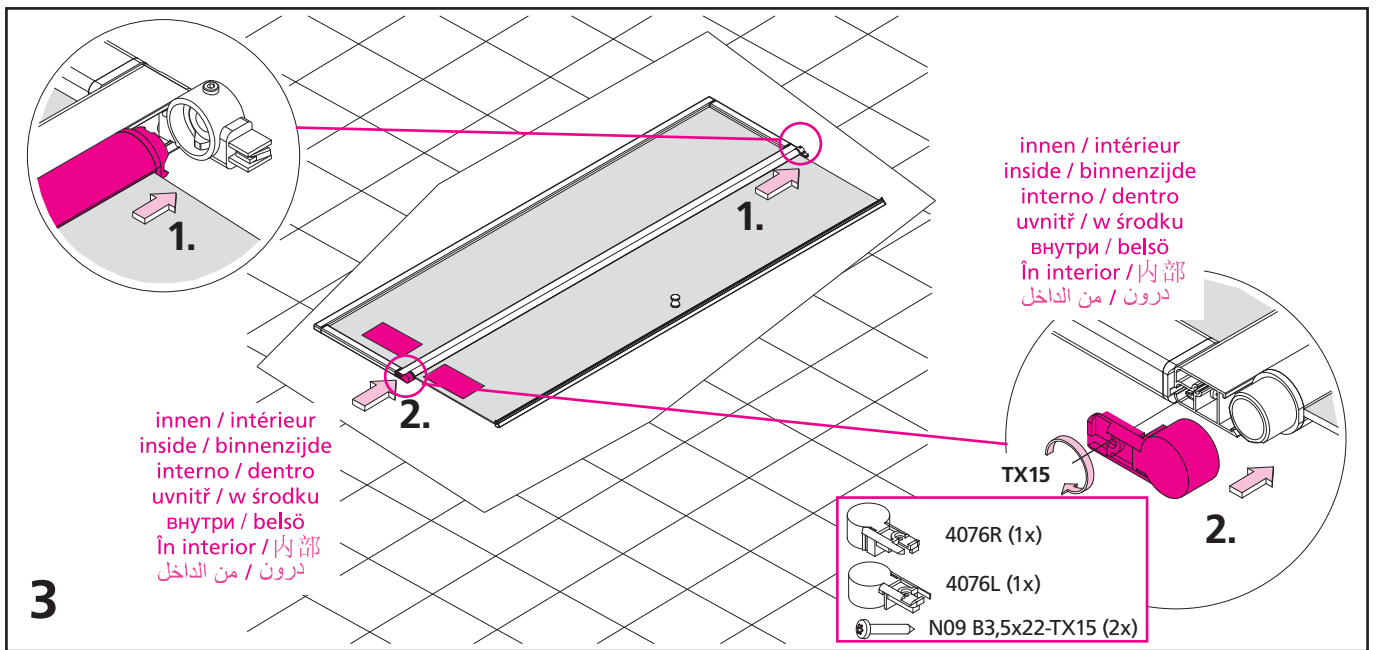

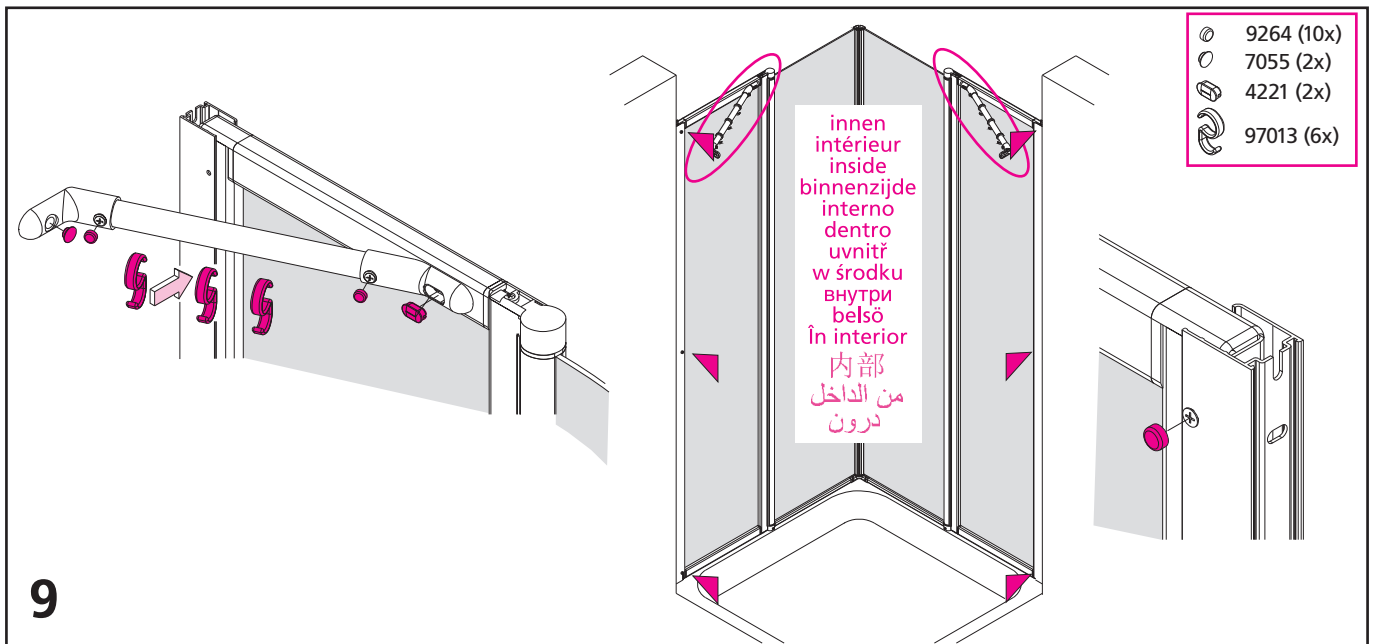
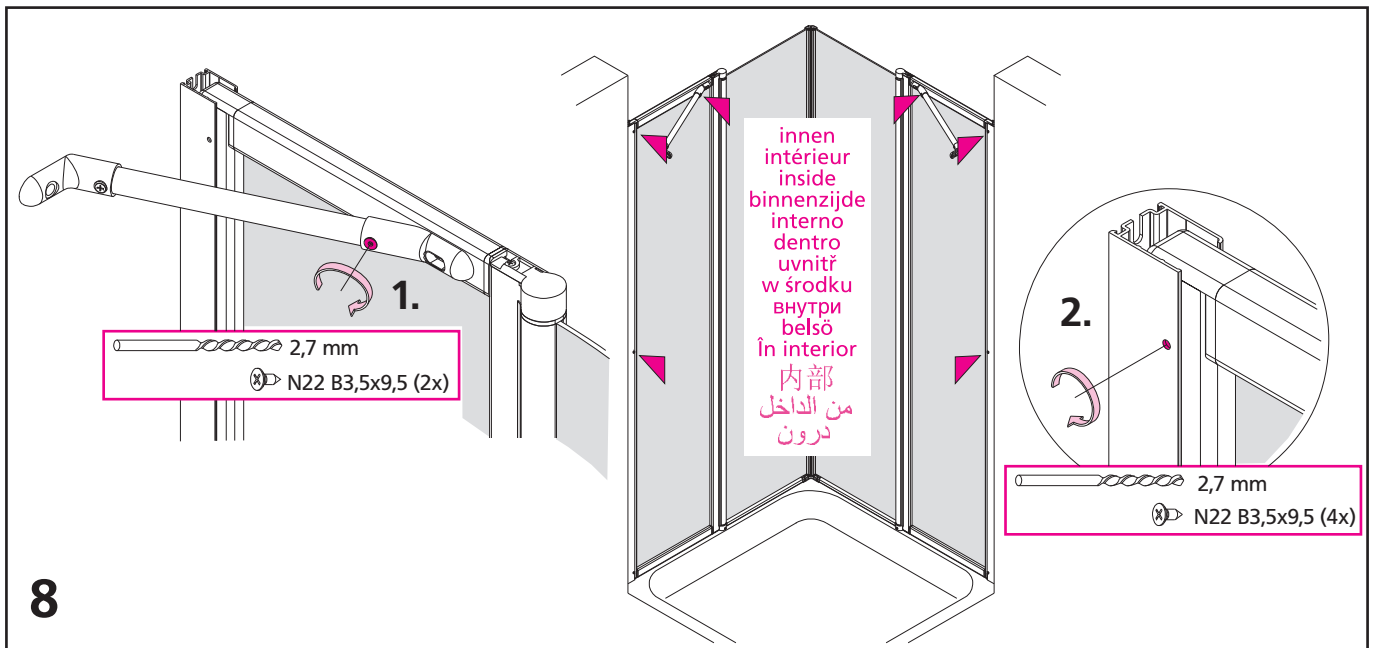
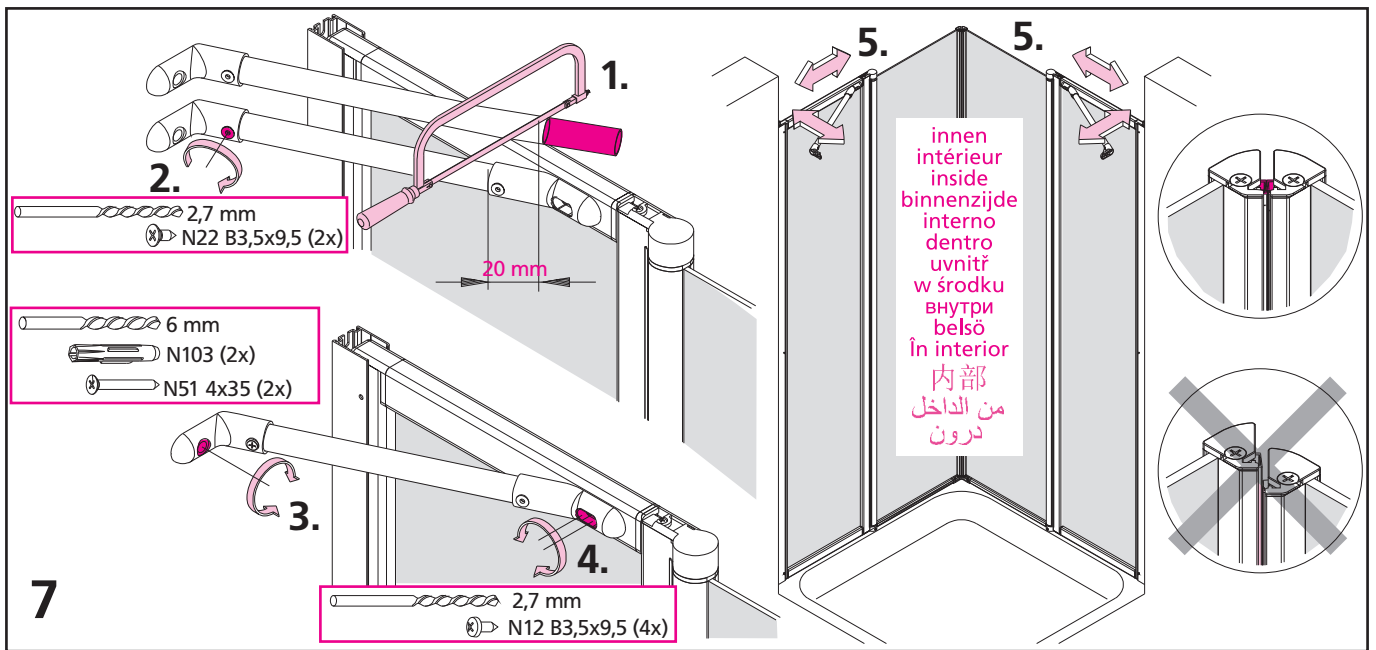

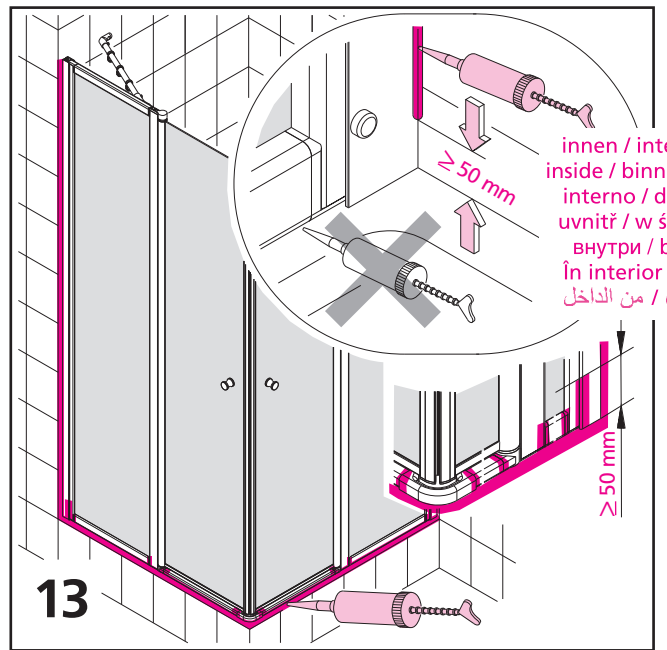
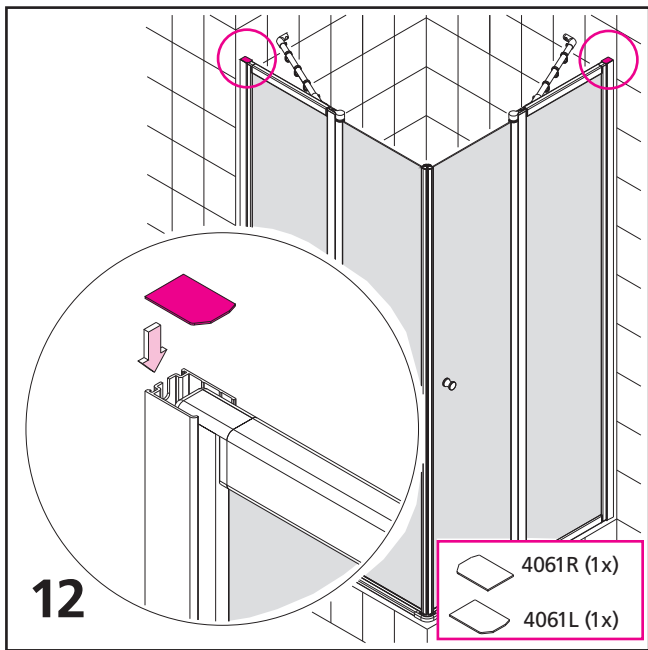
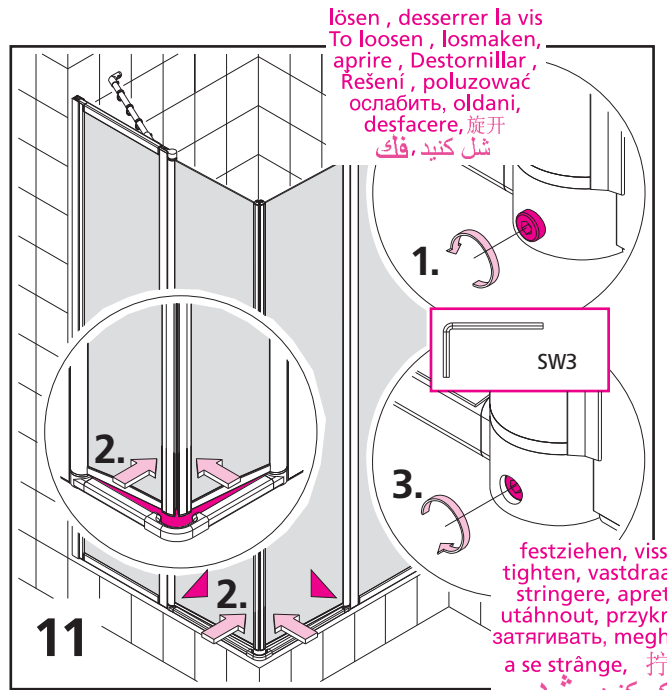
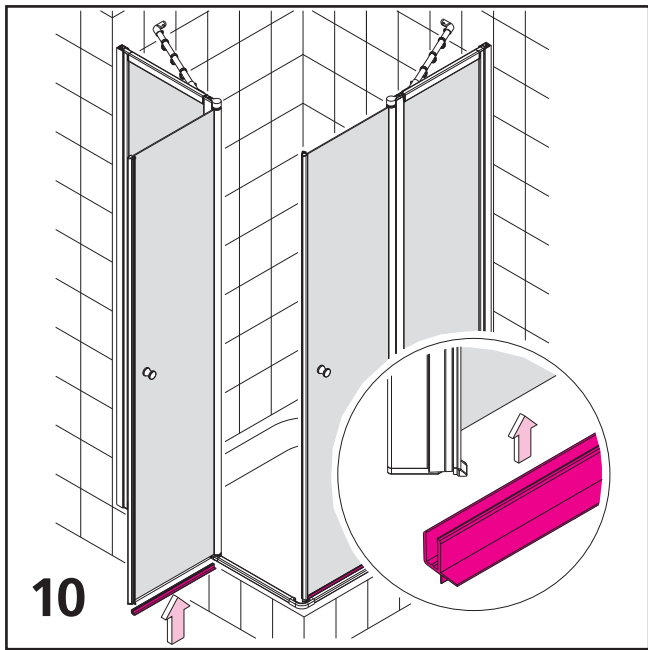

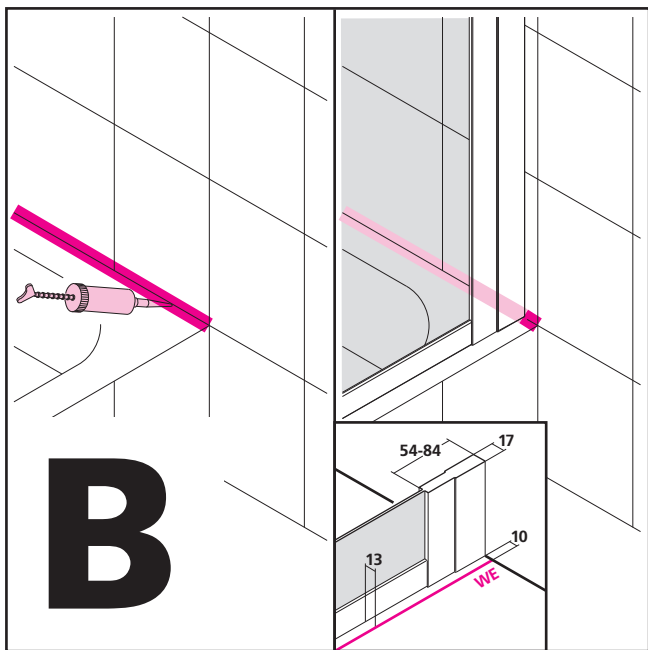

	BV	WE
Typ 70	670-700	680-710
Typ 75	720-750	730-760
Typ 80	770-800	780-810
Typ 90	870-900	880-910
Typ 100	970-1000	980-1010

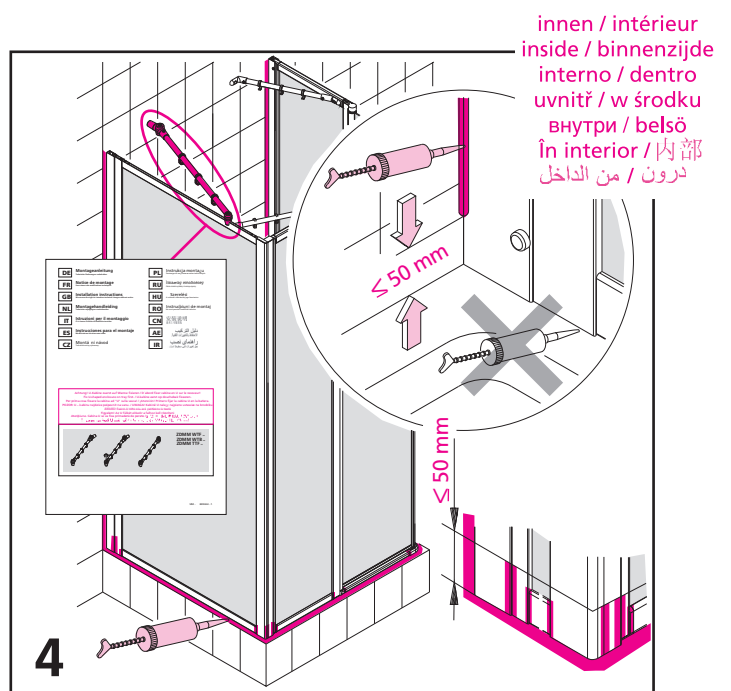
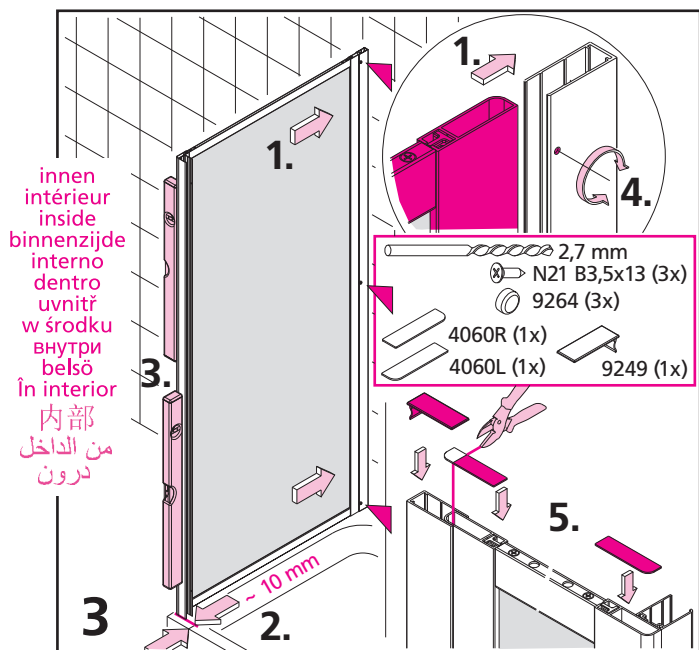
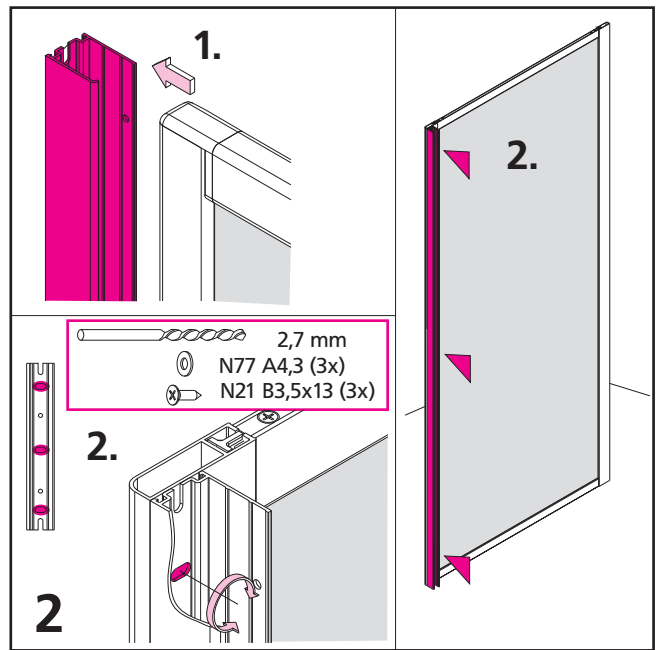
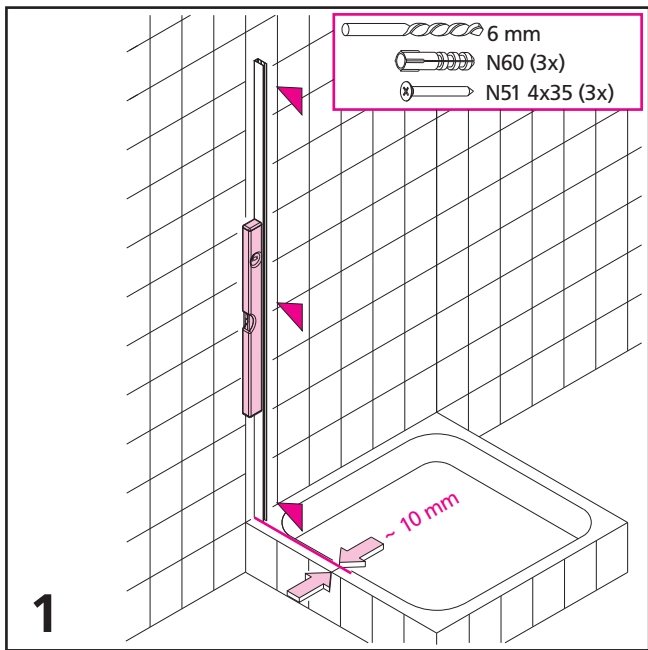

N2 ESL

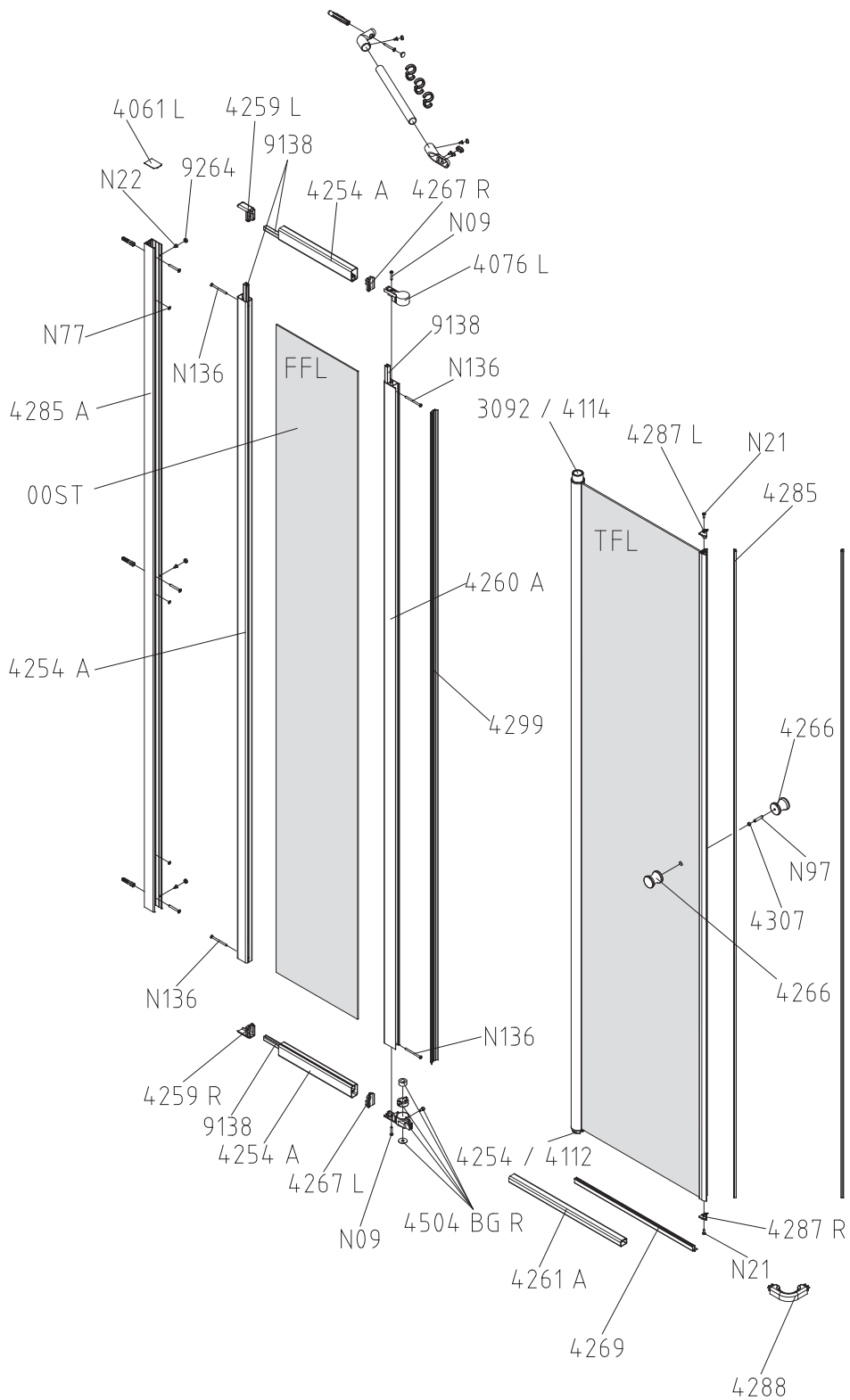

N2 ESR

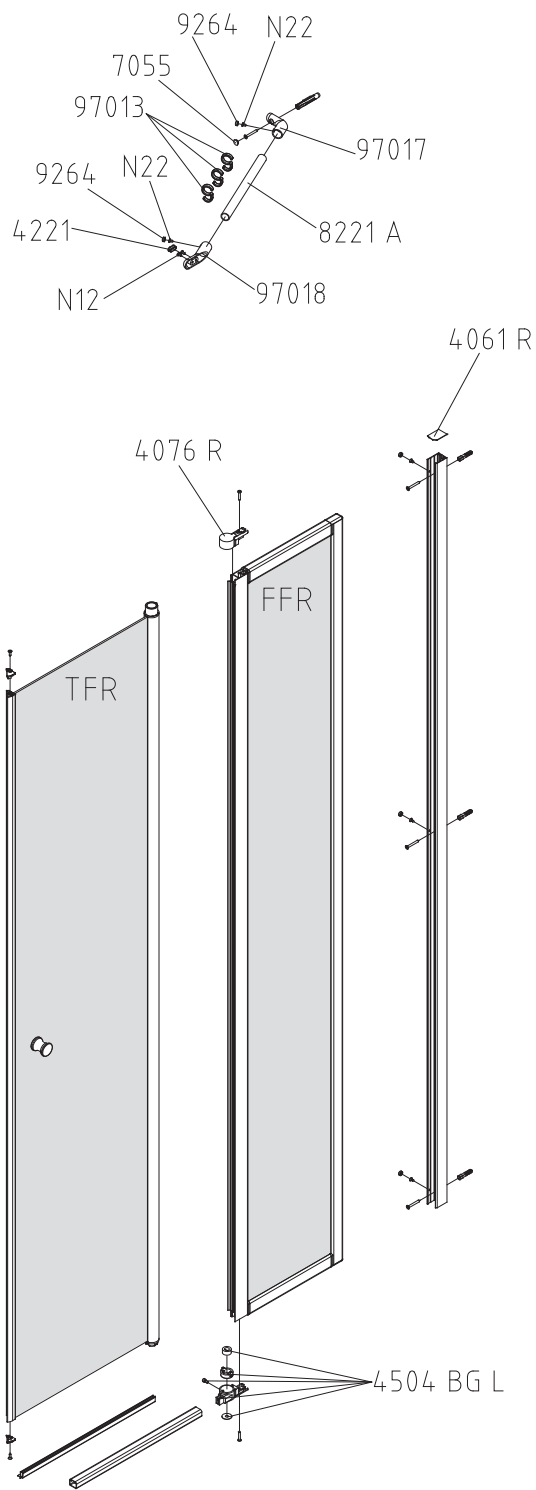

N2 TWD

